



ECH

ECHS

Application

- It is applicable to household water supply, equipment support, pipeline pressurization, garden watering, vegetable greenhouse watering, fish farming and poultry raising, industrial and mining, water supply and drainage of enterprises and high-rise buildings, central air conditioner and centralized heating circulation system, etc.

Pump

- AISI 304 shaft
- Max. liquid temperature: +85°C
- Altitude: up to 1000 m
- Max. suction: 8 m
- Max. inlet pressure: limited by max. operating pressure

Motor

- Motor with copper winding
- Built-in thermal protector for single phase motor
- Insulation class: F
- Protection class: IP44
- Max. ambient temperature: +40°C

Identification Codes

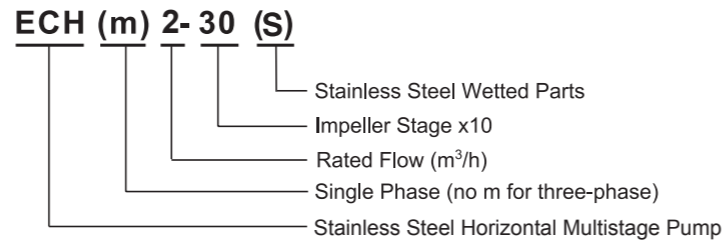

Technical Data

Model	Power		Q (m ³ /h) Q (l/min)	0	0.6	1.2	1.8	2.4	3.0	3.6
	kW	HP		H (m)						
ECH(m)2-20	0.37	0.5	H (m)	18	16	15	13	12	10	8
ECH(m)2-30	0.37	0.5		27	24	22	20	18	16	12
ECH(m)2-40	0.55	0.75		35	33	30	26	24	21	16
ECH(m)2-50	0.55	0.75		45	40	37	33	30	24	19
ECH(m)2-60	0.75	1.0		53	50	45	40	36	30	23

Dimension

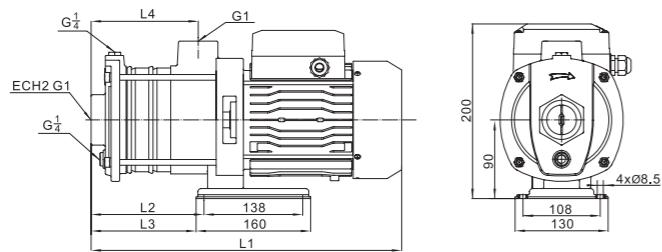

Model	L1	L2	L3	L4	L5	L6	B1	B2	H	H1	A1	A2
ECH(m)2-20	333	75	64	103.5	160	103.5	130	108	200	90	G1	G1
ECH(m)2-30	352	93.5	82.5	122	160	122	130	108	200	90	G1	G1
ECH(m)2-40	370	112	101	140.5	160	140.5	130	108	200	90	G1	G1
ECH(m)2-50	389	130.5	119.5	159	160	159	130	108	200	90	G1	G1
ECH(m)2-60	407	149	138	177.5	160	177.5	130	108	200	90	G1	G1

Hydraulic Performance Curves

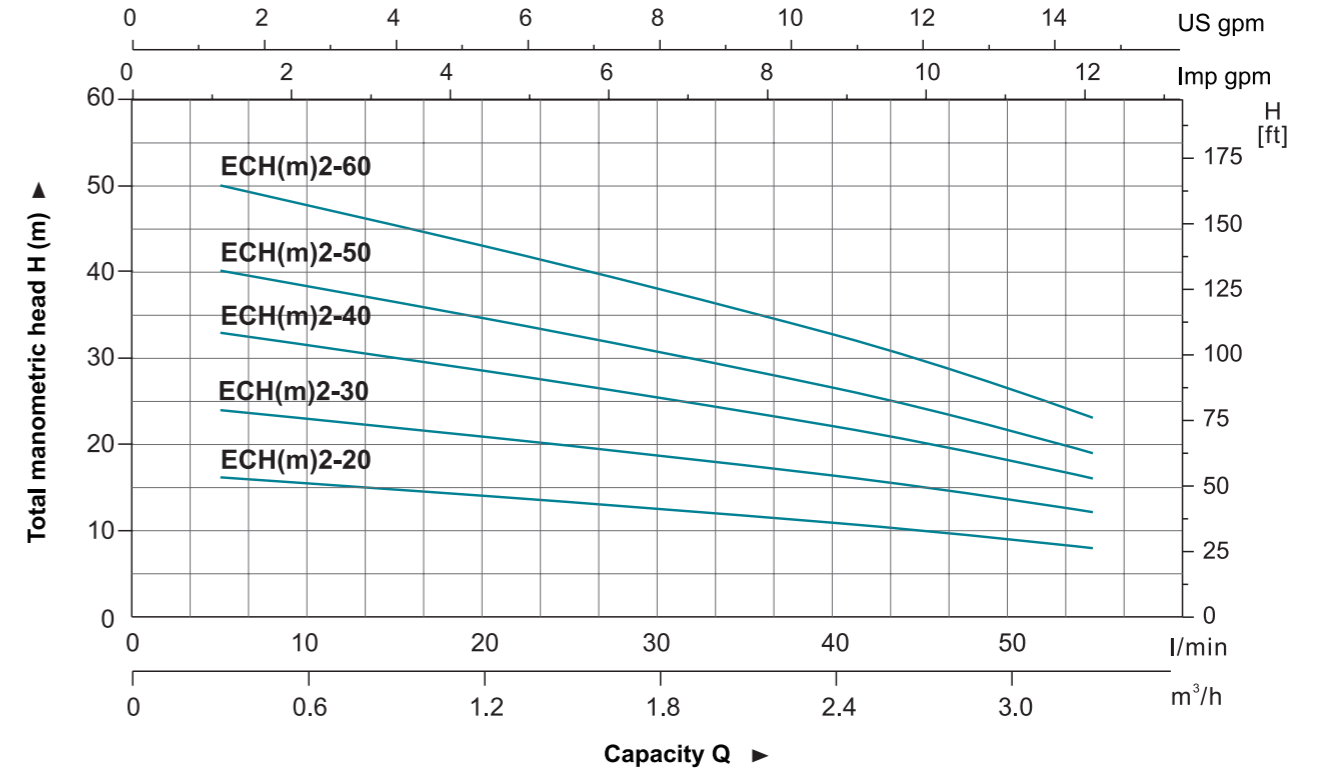

Materials Table

No.	Part	Material
1	Bottom plate	Q235
2	Support	Cast iron/AISI 304
3	Stator	
4	Terminal box	ABS
5	Bearing	
6	Rotor	
7	Rear cover	ZL102
8	Fan	PP
9	Fan cover	Ø8F
10	Mechanical seal	Carbon/Ceramic
11	Diffuser	AISI 304
12	Sleeve	AISI 304
13	Impeller	AISI 304
14	Pump body	Cast iron/AISI 304

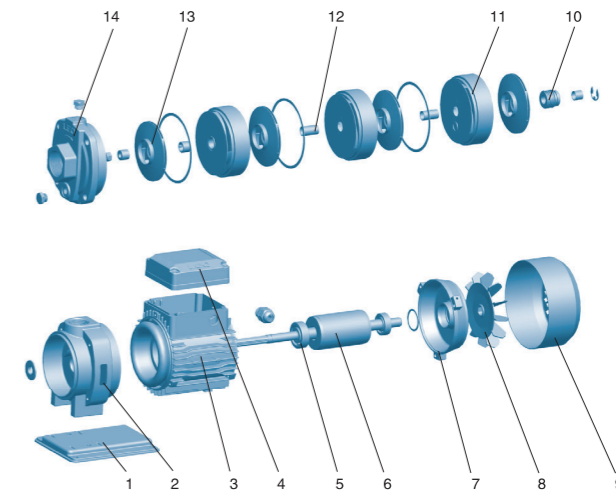

Package Information

Model	GW (Kgs)	L (mm)	W (mm)	H (mm)	Quantity (PCS/20' TEU)
ECH(m)2-20	11.5	400	185	240	1593
ECH(m)2-30	11.8	400	185	240	1593
ECH(m)2-40	12.6	400	185	240	1593
ECH(m)2-50	13.2	455	185	240	1404
ECH(m)2-60	13.7	455	185	240	1404

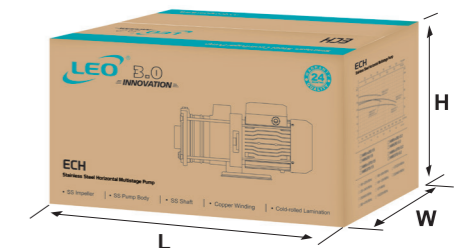

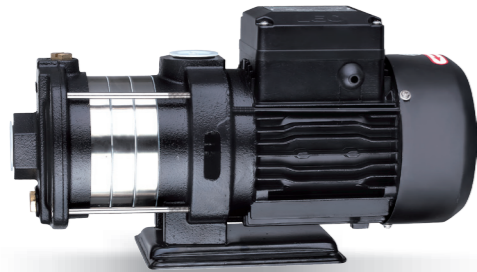

ECH

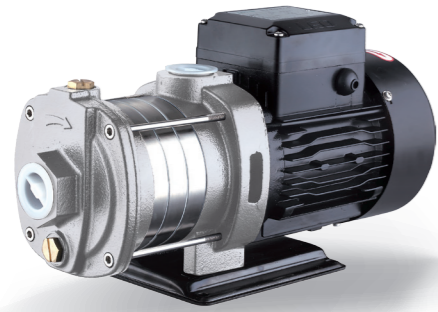

ECHS

Application

- It is applicable to household water supply, equipment support, pipeline pressurization, garden watering, vegetable greenhouse watering, fish farming and poultry raising, industrial and mining, water supply and drainage of enterprises and high-rise buildings, central air conditioner and centralized heating circulation system, etc.

Pump

- AISI 304 shaft
- Max. liquid temperature: +85°C
- Altitude: up to 1000 m
- Max. suction: 8 m
- Max. inlet pressure: limited by max. operating pressure

Motor

- Motor with copper winding
- Built-in thermal protector for single phase motor
- Insulation class: F
- Protection class: IP44
- Max. ambient temperature: +40°C

Identification Codes

ECH (m) 4- 30 (S)

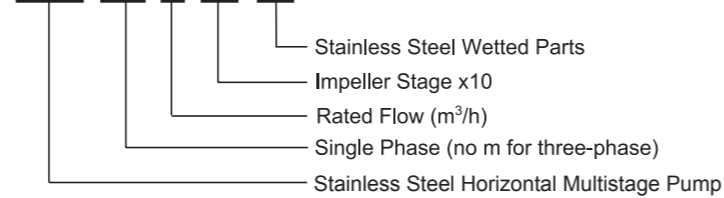

Technical Data

Model	Power		Q (m ³ /h) Q (l/min)	H (m)								
	kW	HP		0	1	2	3	4	5	6	7	
ECH(m)4-20	0.55	0.75	18	17	16	15	13	12	10	8		
ECH(m)4-30	0.55	0.75	28	27	25	23	21	19	16	13		
ECH(m)4-40	0.75	1.0	38	36	34	32	28	26	22	17		
ECH(m)4-50	1.1	1.5	48	46	43	40	36	33	28	21		
ECH(m)4-60	1.1	1.5	58	55	52	48	43	39	33	26		

Dimension

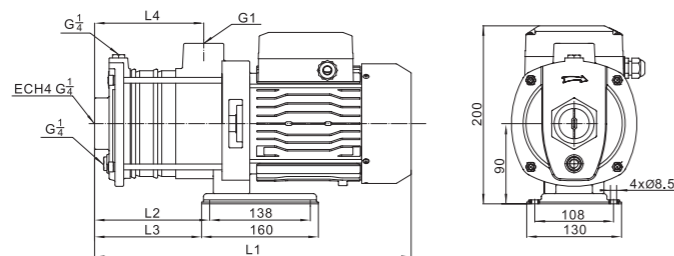

Model	L1	L2	L3	L4	L5	L6	B1	B2	H	H1	A1	A2
ECH(m)4-20	342	85.5	74.5	114	160	114	130	108	200	90	G1 ¹ / ₄	G1
ECH(m)4-30	370	113	102	141.5	160	141.5	130	108	200	90	G1 ¹ / ₄	G1
ECH(m)4-40	398	140.5	129.5	169	160	169	130	108	200	90	G1 ¹ / ₄	G1
ECH(m)4-50	426	168	157	196.5	160	196.5	130	108	200	90	G1 ¹ / ₄	G1
ECH(m)4-60	453	195.5	184.5	224	160	224	130	108	200	90	G1 ¹ / ₄	G1

Hydraulic Performance Curves

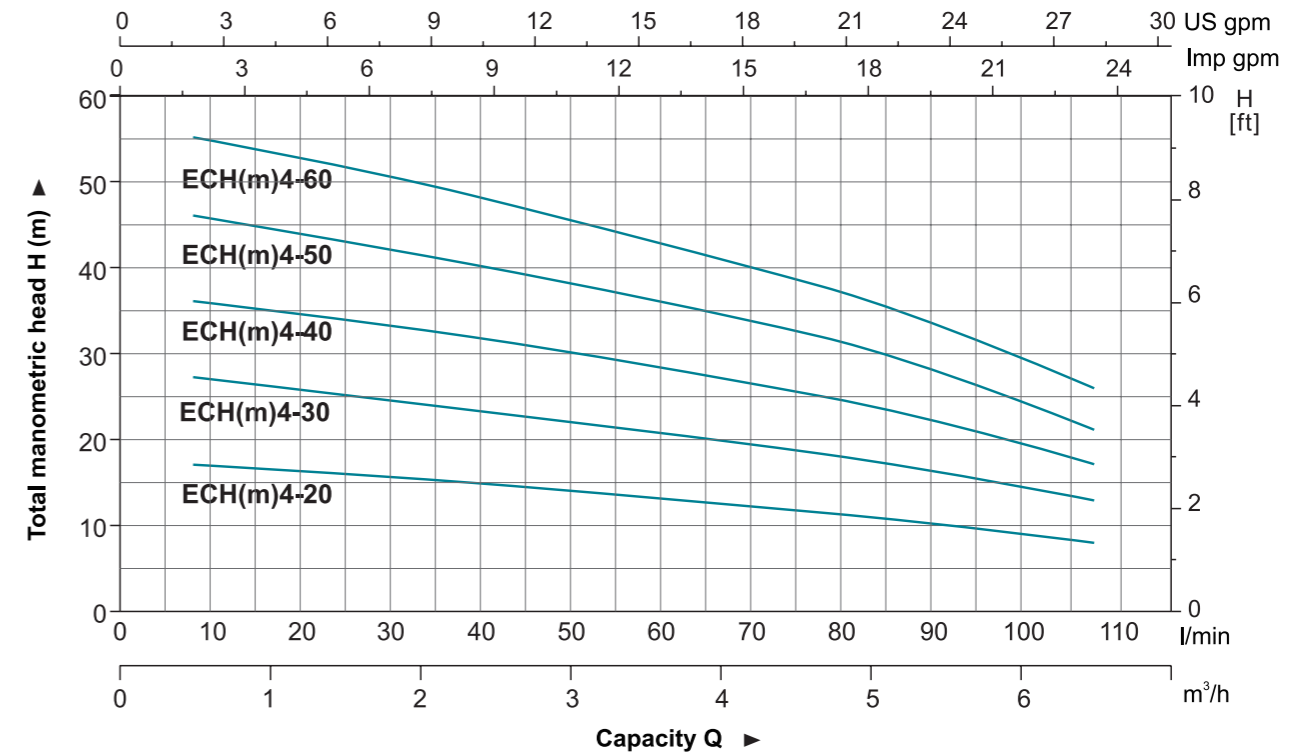

Materials Table

No.	Part	Material
1	Bottom plate	Q235
2	Support	Cast iron/AISI 304
3	Stator	
4	Terminal box	ABS
5	Bearing	
6	Rotor	
7	Rear cover	ZL102
8	Fan	PP
9	Fan cover	08F
10	Mechanical seal	Carbon/Ceramic
11	Diffuser	AISI 304
12	Sleeve	AISI 304
13	Impeller	AISI 304
14	Pump body	Cast iron/AISI 304

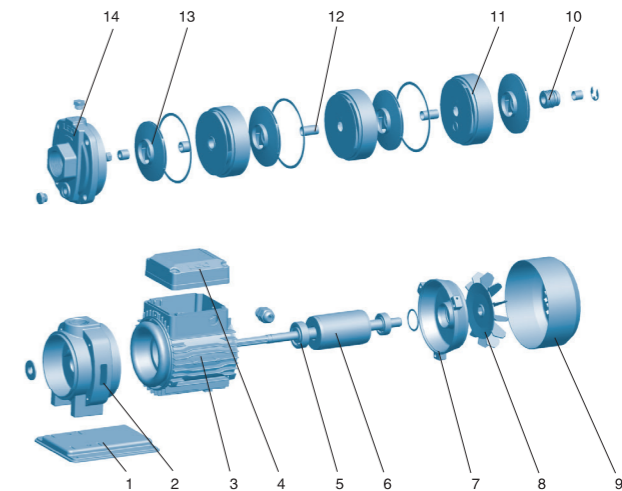

Package Information

Model	GW (Kgs)	L (mm)	W (mm)	H (mm)	Quantity (PCS/20' TEU)
ECH(m)4-20	12.6	400	185	240	1593
ECH(m)4-30	12.8	400	185	240	1593
ECH(m)4-40	14.6	455	185	240	1404
ECH(m)4-50	15.1	455	185	240	1404
ECH(m)4-60	15.6	455	185	240	1287

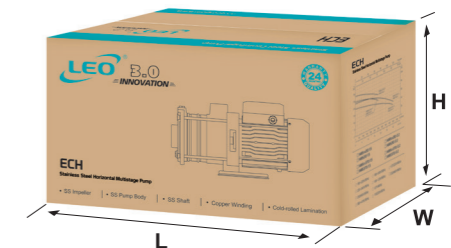

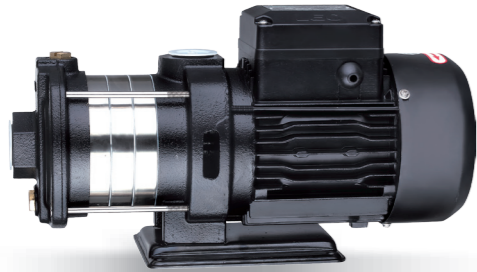

ECH

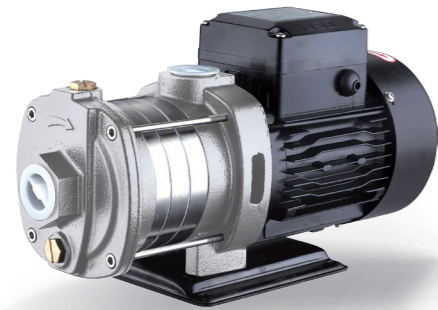

ECHS

Application

- It is applicable to household water supply, equipment support, pipeline pressurization, garden watering, vegetable greenhouse watering, fish farming and poultry raising, industrial and mining, water supply and drainage of enterprises and high-rise buildings, central air conditioner and centralized heating circulation system, etc.

Pump

- AISI 304 shaft
- Max. liquid temperature: +85°C
- Altitude: up to 1000 m
- Max. suction: 8 m
- Max. inlet pressure: limited by max. operating pressure

Motor

- Motor with copper winding
- Built-in thermal protector for single phase motor
- Insulation class: F
- Protection class: IP44
- Max. ambient temperature: +40°C

Identification Codes

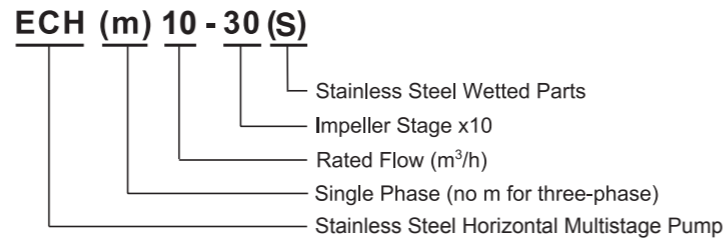

Technical Data

Model	Power		Q (m ³ /h)	Q (l/min)												
	kW	HP		0	1	2	3	4	5	6	7	8	9	10	11	12
ECH(m)10-10	0.75	1.0	H (m)	10.1	10.0	9.8	9.7	9.6	9.4	9.1	8.7	8.2	7.7	6.8	5.8	4.8
ECH(m)10-20				19.5	19.3	19.0	18.9	18.7	18.4	17.9	17.1	16.3	15.3	14.0	12.5	10.6
ECH(m)10-30	1.1	1.5		29.3	28.9	28.6	28.5	28.3	27.7	27.1	26.3	24.9	23.4	21.4	19.3	16.9
ECH(m)10-40	1.5	2.0		40.0	40.0	39.6	39.7	39.8	39.2	38.6	37.6	35.9	33.9	31.2	28.2	24.6
ECH(m)10-50	2.2	3.0		49.9	49.6	49.2	48.9	49.1	48.6	47.8	46.4	44.4	42.2	39.5	35.9	31.1

Dimension

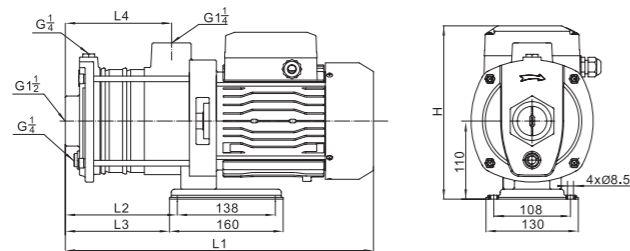

Model	L1	L2	L3	L4	L5	L6	B1	B2	H	H1	A1	A2
ECH(m)10-10	398	122	111	120	160	120	130	108	235	110	G1 ¹ / ₂	G1 ¹ / ₄
ECH(m)10-20	398	122	111	120	160	120	130	108	235	110	G1 ¹ / ₂	G1 ¹ / ₄
ECH(m)10-30	428	152	141	150	160	150	130	108	235	110	G1 ¹ / ₂	G1 ¹ / ₄
ECH(m)10-40	530	194	183	187	160	187	130	108	244	110	G1 ¹ / ₂	G1 ¹ / ₄
ECH(m)10-50	560	224	213	217	160	217	130	108	244	110	G1 ¹ / ₂	G1 ¹ / ₄

Hydraulic Performance Curves

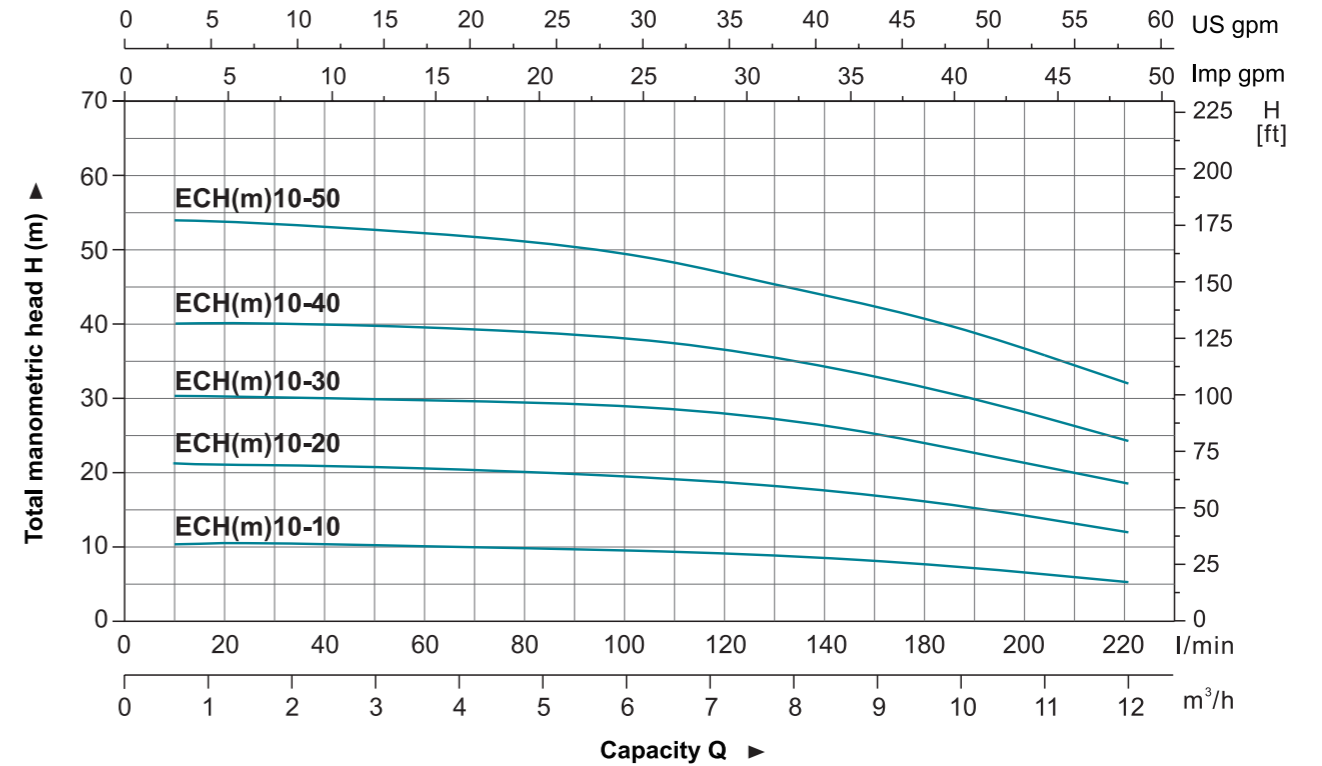

Materials Table

No.	Part	Material
1	Bottom plate	Q235
2	Support	Cast iron/AISI 304
3	Stator	
4	Terminal box	ABS
5	Bearing	
6	Rotor	
7	Rear cover	ZL102
8	Fan	PP
9	Fan cover	08F
10	Mechanical seal	Carbon/Ceramic
11	Diffuser	AISI 304
12	Sleeve	AISI 304
13	Impeller	AISI 304
14	Pump body	Cast iron/AISI 304

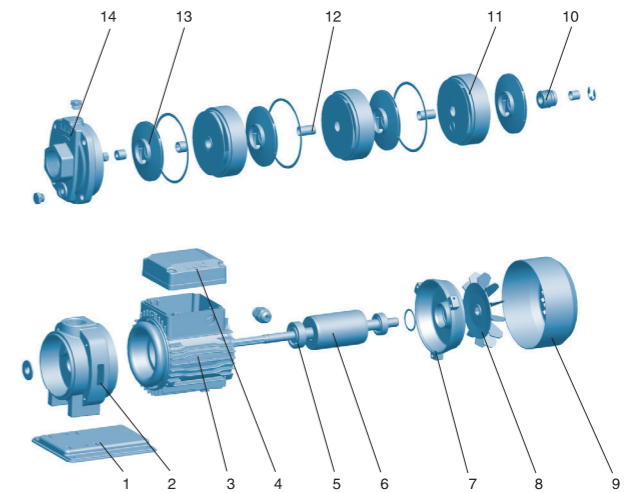

Package Information

Model	GW (Kgs)	L (mm)	W (mm)	H (mm)	Quantity (PCS/20' TEU)
ECH(m)10-10	21.7	435	230	282	910
ECH(m)10-20	21.8	435	230	282	910
ECH(m)10-30	23.7	465	230	282	843
ECH(m)10-40	26.1	570	230	282	700
ECH(m)10-50	29.9	600	230	282	658

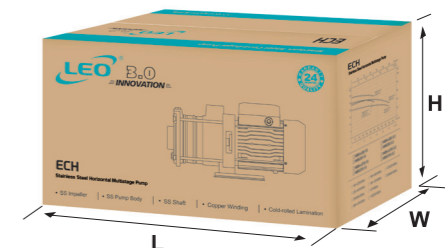

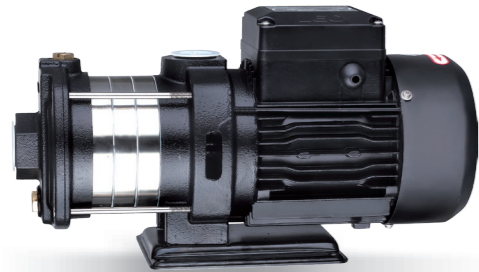

ECH

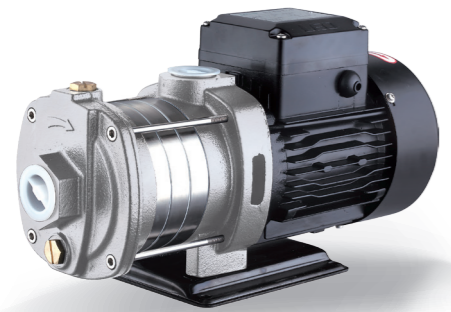

ECHS

Application

- It is applicable to household water supply, equipment support, pipeline pressurization, garden watering, vegetable greenhouse watering, fish farming and poultry raising, industrial and mining, water supply and drainage of enterprises and high-rise buildings, central air conditioner and centralized heating circulation system, etc.

Pump

- AISI 304 shaft
- Max. liquid temperature: +85°C
- Altitude: up to 1000 m
- Max. suction: 8 m
- Max. inlet pressure: limited by max. operating pressure

Motor

- Motor with copper winding
- Built-in thermal protector for single phase motor
- Insulation class: F
- Protection class: IP44
- Max. ambient temperature: +40°C

Identification Codes

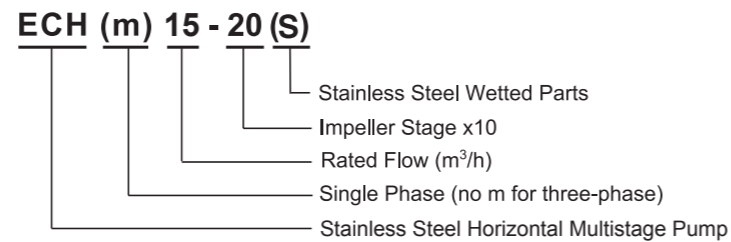

Technical Data

Model	Power		Q (m³/h) Q (l/min)	0	3	6	9	12	15	18	21
	kW	HP		H (m)							
ECH(m)15-10	1.1	1.5		13.9	13.5	13.1	12.4	11.6	10.6	9.4	8.2
ECH(m)15-20	2.2	3		27.8	27.5	26.7	25.6	24.1	22.7	21.1	18.8
ECH15-30	3.0	4		42.1	40.9	39.8	38.7	36.9	34.9	31.9	28.5
ECH15-40	4.0	5.5		55.5	54.3	52.8	51.8	49.7	46.8	42.9	38.3

Dimension

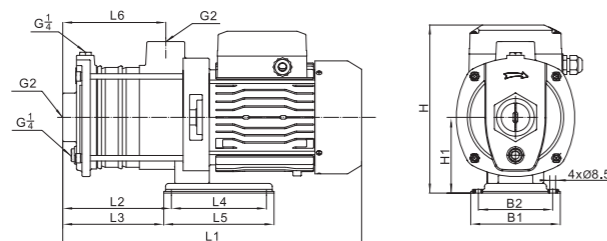

Model	L1	L2	L3	L4	L5	L6	B1	B2	H	H1	A1	A2
ECH(m)15-10	419	142	131	138	160	142	130	108	235	110	G2	G2
ECH(m)15-20	485	149	138	138	160	142	130	108	244	110	G2	G2
ECH15-30	546	192	172	190	230	185	180	140	261	120	G2	G2
ECH15-40	591	237	217	190	230	230	180	140	261	120	G2	G2

Hydraulic Performance Curves

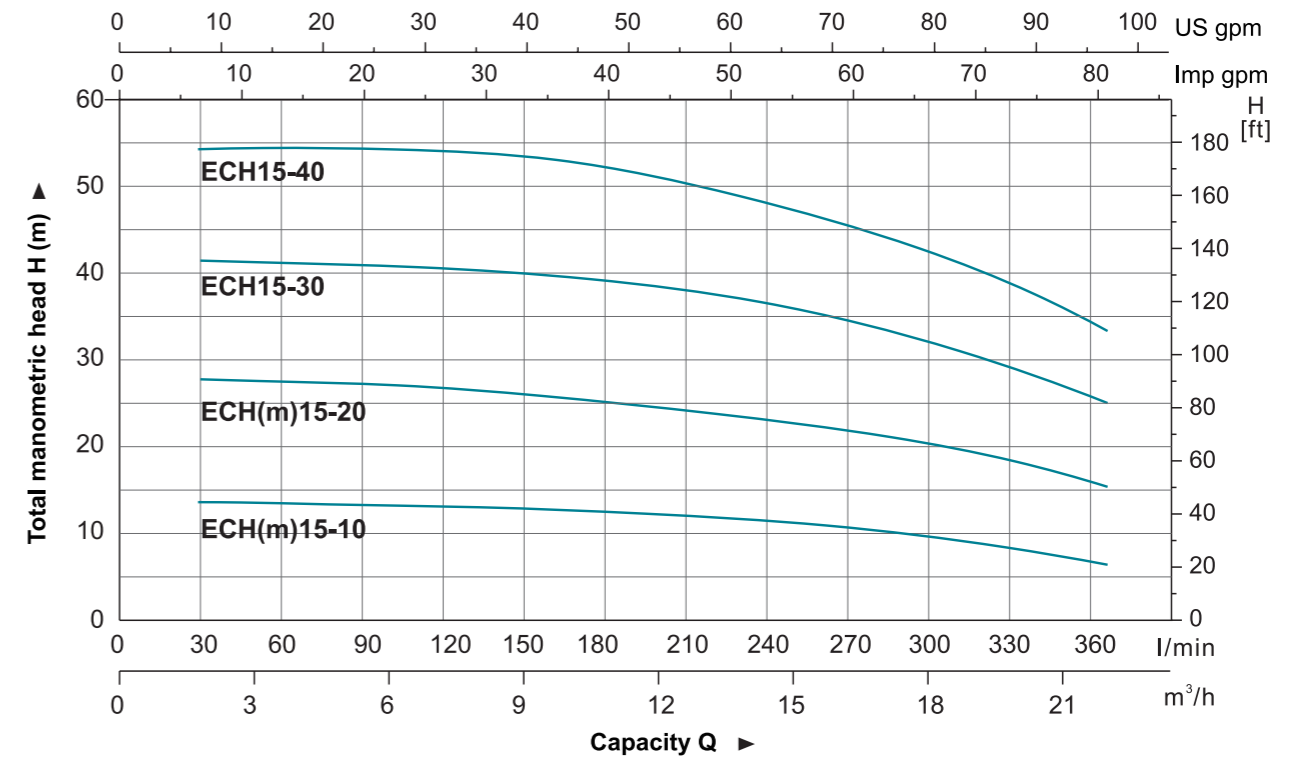

Materials Table

No.	Part	Material
1	Bottom plate	Q235
2	Support	Cast iron/AISI 304
3	Stator	
4	Terminal box	ABS
5	Bearing	
6	Rotor	
7	Rear cover	ZL102
8	Fan	PP
9	Fan cover	08F
10	Mechanical seal	Carbon/Ceramic
11	Diffuser	AISI 304
12	Sleeve	AISI 304
13	Impeller	AISI 304
14	Pump body	Cast iron/AISI 304

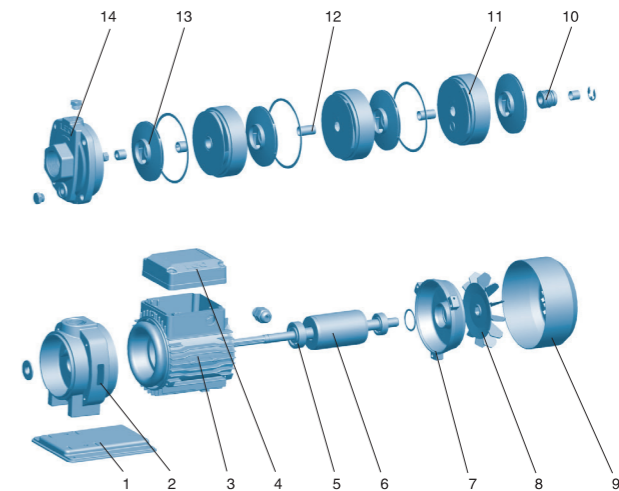

Package Information

Model	GW (Kgs)	L (mm)	W (mm)	H (mm)	Quantity (PCS/20 TEU)
ECH(m)15-10	22.9	465	230	282	854
ECH(m)15-20	28.7	530	230	282	696
ECH15-30	34.5	585	275	302	553
ECH15-40	38.1	640	275	302	524

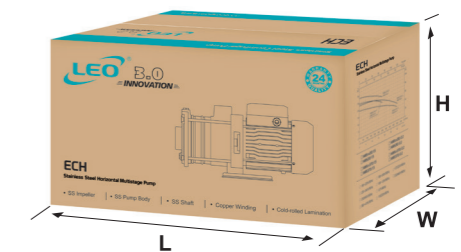

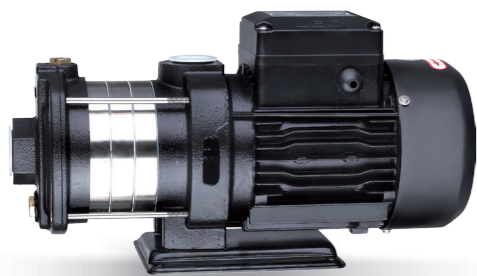

ECH

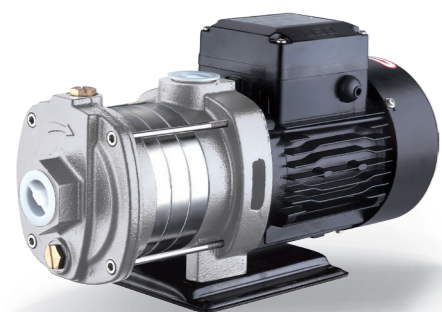

ECHS

Application

- It is applicable to household water supply, equipment support, pipeline pressurization, garden watering, vegetable greenhouse watering, fish farming and poultry raising, industrial and mining, water supply and drainage of enterprises and high-rise buildings, central air conditioner and centralized heating circulation system, etc.

Pump

- AISI 304 shaft
- Max. liquid temperature: +85°C
- Altitude: up to 1000 m
- Max. suction: 8 m
- Max. inlet pressure: limited by max. operating pressure

Motor

- Motor with copper winding
- Built-in thermal protector for single phase motor
- Insulation class: F
- Protection class: IP44
- Max. ambient temperature: +40°C

Identification Codes

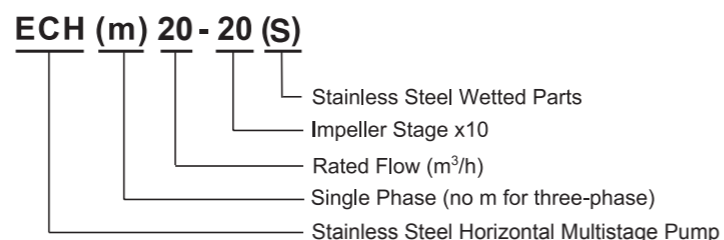

Technical Data

Model	Power		Q (m ³ /h) Q (l/min)	0	4	8	12	16	20	24	28
	kW	HP		H (m)							
ECH(m)20-10	1.1	1.5	H (m)	13.6	13.3	12.8	12.1	10.8	9.5	7.8	5.7
ECH(m)20-20	2.2	3		28.5	27.8	27.0	26.1	24.4	22.4	19.8	17.2
ECH20-30	4.0	5.5		42.5	41.6	40.9	39.9	38.0	35.5	31.4	26.9
ECH20-40				56.6	55.2	54.2	52.7	50.1	45.9	40.3	34.0

Dimension

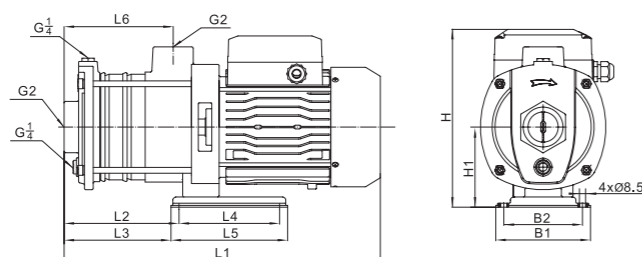

Model	L1	L2	L3	L4	L5	L6	B1	B2	H	H1	A1	A2
ECH(m)20-10	419	142	131	138	160	142	130	108	235	110	G2	G2
ECH(m)20-20	485	149	138	138	160	142	130	108	244	110	G2	G2
ECH20-30	546	192	172	190	230	185	180	140	261	120	G2	G2
ECH20-40	591	237	217	190	230	230	180	140	261	120	G2	G2

Hydraulic Performance Curves

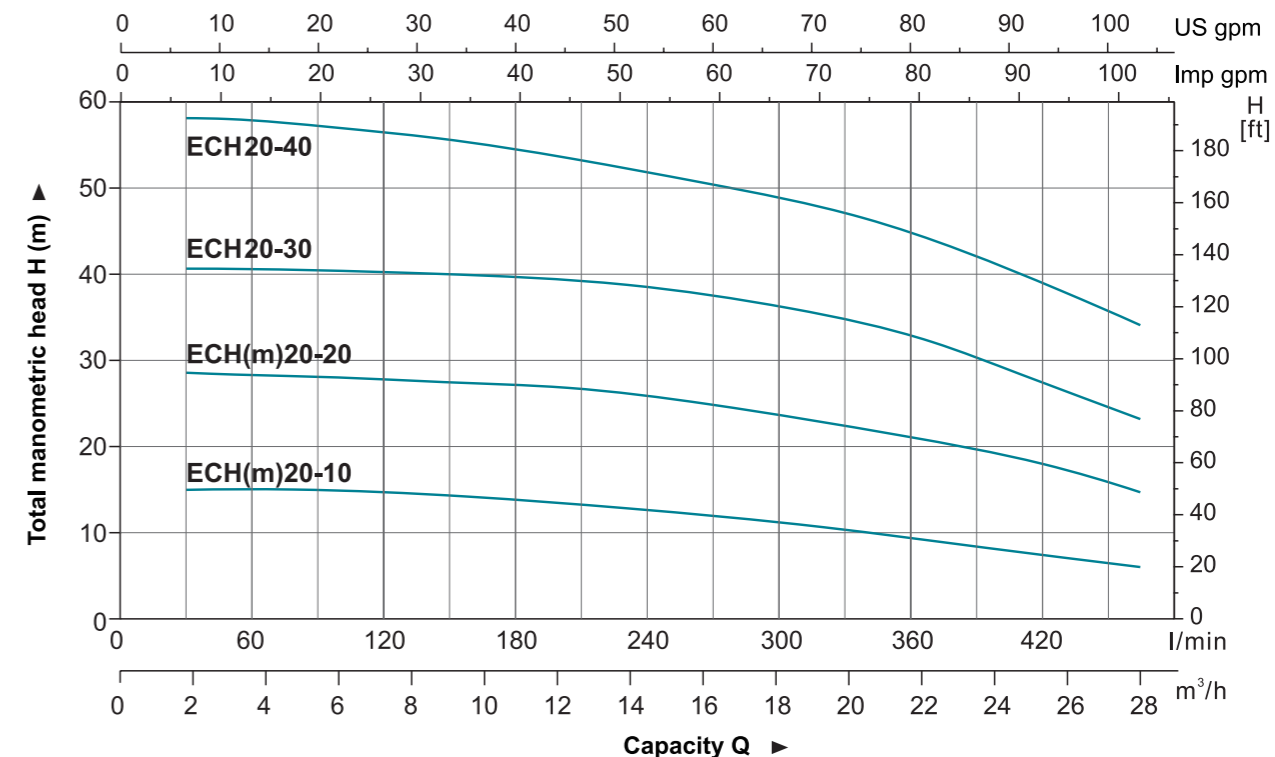

Materials Table

No.	Part	Material
1	Bottom plate	Q235
2	Support	Cast iron/AISI 304
3	Stator	
4	Terminal box	ABS
5	Bearing	
6	Rotor	
7	Rear cover	ZL102
8	Fan	PP
9	Fan cover	08F
10	Mechanical seal	Carbon/Ceramic
11	Diffuser	AISI 304
12	Sleeve	AISI 304
13	Impeller	AISI 304
14	Pump body	Cast iron/AISI 304

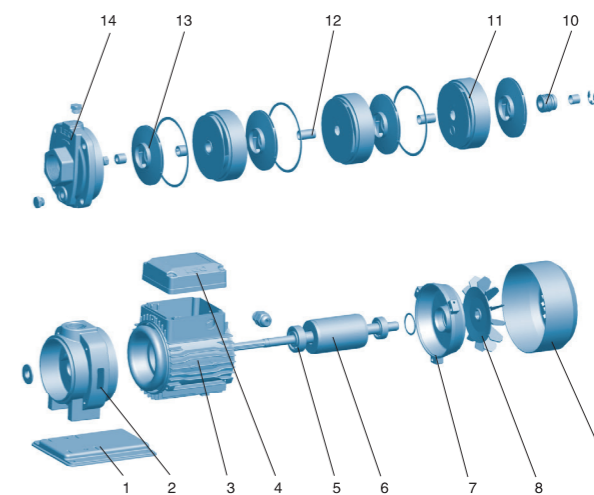

Package Information

Model	GW (Kgs)	L (mm)	W (mm)	H (mm)	Quantity (PCS/20 TEU)
ECH(m)20-10	22.9	465	230	282	854
ECH(m)20-20	28.7	530	230	282	696
ECH20-30	37.3	585	275	302	536
ECH20-40	38.1	640	275	302	524

