

شرکت فن آوران تهویه پیام  
نماینده رسمی و انحصاری فروش و خدمات پس از فروش محصولات لیو در ایران



## Pumps

- Circulation Pump
- Booster Pump



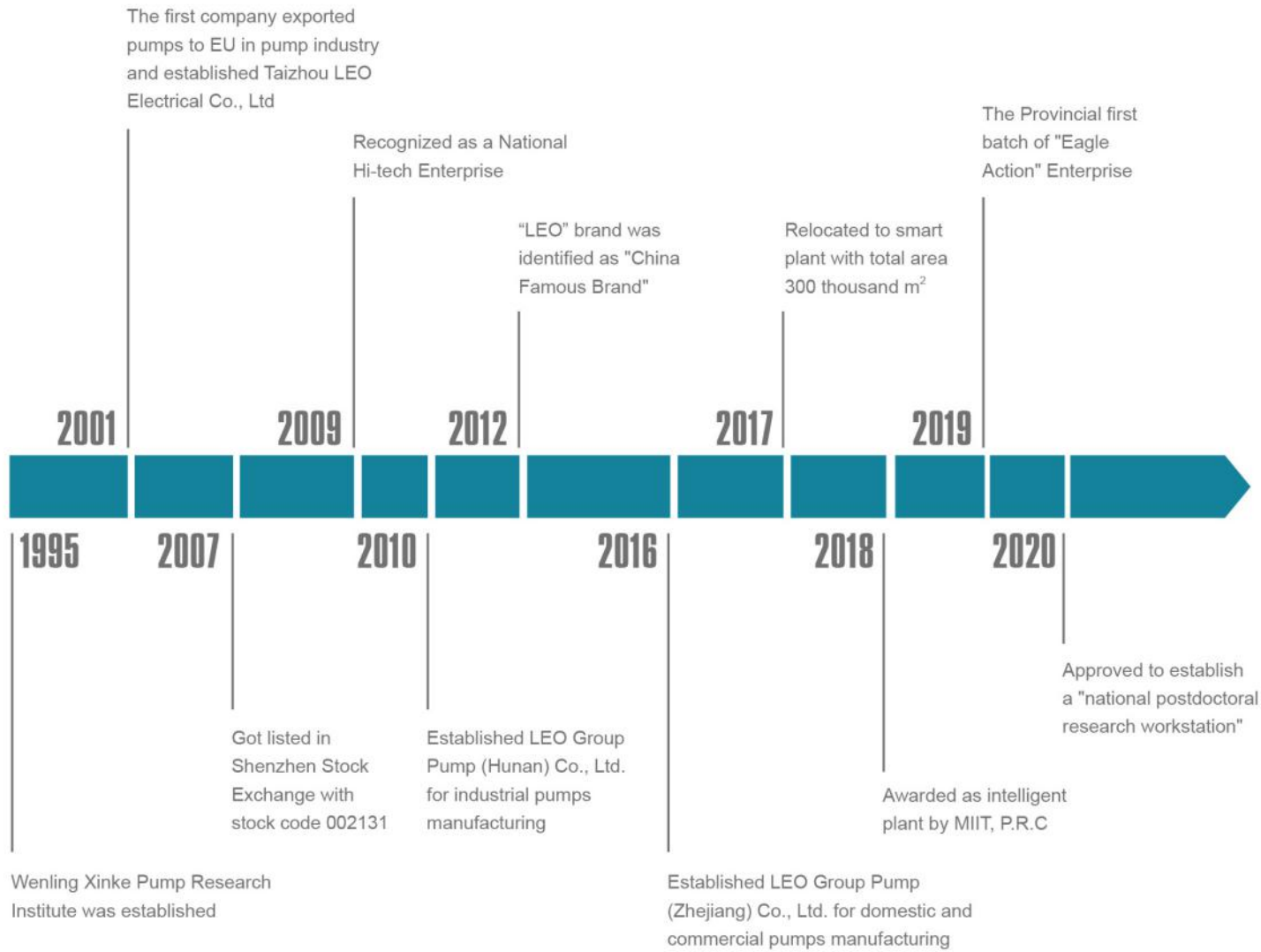

TO KNOW LEO



1<sup>st</sup> LISTED PUMP MANUFACTURER

850 ENGINEERS AND 4000 EMPLOYEES IN TOTAL

GLOBAL AUTHORIZED DISTRIBUTOR OVER 140 COUNTRIES AND REGIONS

MORE THAN 15,000 SALES OUTLETS SERVED OVER 500 MILLION USERS

OVER 6,000,000 PUMPS PRODUCED YEARLY





## NUMEROUS MEMBERS, ONE FAMILY

Based on market segment, LEO's pump business is divided into 5 fields, namely water conservancy & water resources, power station, petrochemical industry, mining & metallurgical industry and civilian applications. For each field there's a professional manufacturing base with relevant professional sales teams. Two pump manufacturing bases, LEO Group Pump (Hunan) and Dalian LEO Pump are all well-known industrial pump manufacturers in their own fields. With over 70 years' industrial pump manufacturing experience and extraordinary comprehensive strength, LEO has become a leading company among all industrial pump manufacturers in China.

### Pump Manufacturing Base for Domestic and Commercial Applications (Wenling City, Zhejiang Province)



Area: Around 246,666 m<sup>2</sup>

Product scope: Peripheral Pump, Jet Pump, Centrifugal Pump, Garden Submersible Pump, Fountain Pump, Pool Pump, Domestic Lifting Pump, Gasoline Engine Pump, Diesel Engine Pump, Submersible Pump, Submersible Borehole Pump, Submersible Sewage Pump, Stainless Steel Vertical Multistage Pump, etc.

### Pump Manufacturing Base for General Industrial Pumps (Xiangtan City, Hunan Province)



Area: Around 92,635 m<sup>2</sup>

Product scope: Large Mixed Flow And Axial Flow Pump (Vertical, Horizontal, Oblique, Tubular, Submersible etc.), Double-Suction Centrifugal Pump, Multistage Centrifugal Pump, Slurry Pump, Desulphurization Pump And Submersible Centrifugal Pump. Products are mainly used in mine, metallurgy, coal washing, FGD, municipal water etc.

### Pump Manufacturing Base for Petrochemical Industry (Dalian City, Liaoning Province)



Area: Around 10,000 m<sup>2</sup>

Product Scope: Petrochemical Pumps, specializes in R&D, design of pumps of petro chemistry, coal chemical industry, long-distance transport pipes, energy resources, fine chemicals industry, etc. Design and develop software and large laboratories, explore liquid transport schemes under severe conditions and solve the difficult projects of ultralow temperature, high temperature high pressure, low cavitation, highly corrosive, energy recovery, etc.





• Peripheral Pump



• Self-Priming Peripheral Pump



• Jet Pump



• Jet Pump for Deep Wells



• Centrifugal Pump



• Multistage Centrifugal Pump



• Self-Priming Centrifugal Pump



• Stainless Steel Multistage Centrifugal Pump



• Stainless Steel Centrifugal Pump



• Submersible Pump



• Stainless Steel Submersible Pump



• Flexible Shaft Pump



• Domestic Lifting Station



• Pool Pump



• Fountain Pump



• Garden Submersible Pump



• Garden Jet Pump



• Garden Pressure System



• Petrol Lawnmowers



• Gasoline Pressure Washers



• Booster Pump/Circulation Pump



• Wall-Mounted Gas Boiler Pump



• Stainless Steel Horizontal Multistage Pump



• Stainless Steel Horizontal Multistage Pump



• Semi-open Impeller Stainless Steel Centrifugal Pump



• Intelligent Pressure Booster System



• Permanent Magnet Intelligent Booster



• Standard Centrifugal Pump



• Stainless Steel Standard Centrifugal Pump



• Submersible Sewage Pump



• Submersible Sewage Pump



• Submersible Dewatering Pump



• Submersible Slurry Pump



• Vertical In-line Pump



• Stainless Steel Vertical Multistage Pump



• Pressure Booster System



• End Suction Centrifugal Pump



• Gasoline/Diesel Water Pump



• Generators



• Submersible Borehole Pump



• Solar Submersible Pump Systems





### Application

- It is widely used for heating ventilating and air conditioning (HVAC) circulation, pressure boosting of hot water in family, homes powered by solar energy, industrial auxiliary equipment cold and hot water circulation and so forth
- Water circulation for the central and district heating system
- Domestic hot water circulation

### Pump

- Bronze or anti-rust cast iron pump body
- Noryl impeller with heat resistance up to 150°C
- 95% alumina ceramic shaft
- Liquid temperature: 2°C - 110°C

### Motor

- Insulation class: H
- Protection class: IP44
- 99% alumina ceramic bearing
- Copper winding
- Three speed motor

### Identification Codes

#### LRP 15 - 50 B / 130

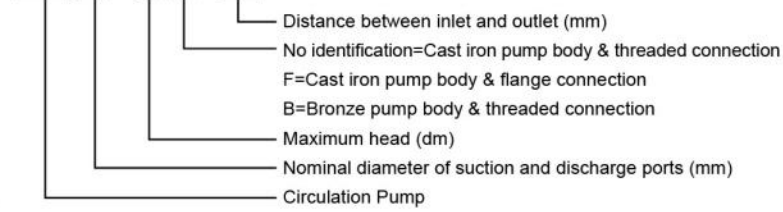

#### Connectors on request



Model	L (mm)	B (mm)	B1 (mm)	H (mm)	H1 (mm)	G
LRP15-40/130	130	125	75	130	25	G1
LRP15-40B/130	130	125	75	130	25	G1
LRP20-40/130	130	125	75	130	25	G1.25
LRP25-40/130	130	125	75	130	25	G1.5
LRP25-40/180	180	125	75	130	25	G1.5
LRP32-40/180	180	125	75	135	30	G2
LRP15-50/130	130	125	75	130	25	G1
LRP15-50B/130	130	125	75	130	25	G1
LRP20-50/130	130	125	75	130	25	G1.25
LRP25-50/130	130	125	75	130	25	G1.5
LRP25-50/180	180	125	75	130	25	G1.5
LRP32-50/180	180	125	75	135	30	G2
LRP15-60/130	130	125	75	130	25	G1
LRP15-60B/130	130	125	75	130	25	G1
LRP20-60/130	130	125	75	130	25	G1.25
LRP25-60/130	130	125	75	130	25	G1.5
LRP25-60/180	180	125	75	130	25	G1.5
LRP32-60/180	180	125	75	135	30	G2
LRP25-70/130	130	125	75	130	25	G1.5
LRP25-70/180	180	125	75	130	25	G1.5
LRP32-70/180	180	125	75	135	30	G2
LRP25-80/180	180	134	75	154	25	G1.5
LRP25-120/180	180	148	75	155	25	G1.5
LRP32-80/180	180	137	75	168	40	G2

### Dimension Drawing

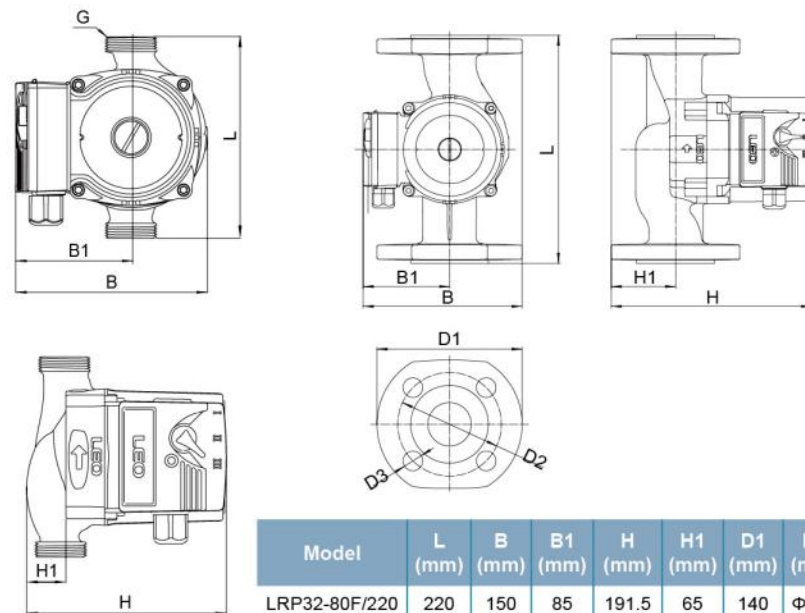

Model	L (mm)	B (mm)	B1 (mm)	H (mm)	H1 (mm)	D1 (mm)	D2 (mm)	D3 (mm)
LRP32-80F/220	220	150	85	191.5	65	140	Φ100	Φ19
LRP36-80F/200	200	138	85	174.5	45	90	Φ90	Φ11.5
LRP40-80F/250	250	155	85	196.5	70	150	Φ110	Φ19

Model	Voltage /Frequency (V/Hz)	Power(W)			Max. Flow (l/min)	Max. Head (m)	N.W. (kgs)	G.W. (kgs)	Packing Size (mm)
		3	2	1					
LRP15-40/130	220~240/50Hz	67	58	40	46/42/30	4.5/4.4/3.6	2.32	2.45	165x150x140
LRP15-40B/130	220~240/50Hz	67	58	40	46/42/30	4.5/4.4/3.6	2.41	2.54	165x150x140
LRP20-40/130	220~240/50Hz	68	59	40	51/46/32	4.3/4.1/3.6	2.37	2.5	165x150x140
LRP25-40/130	220~240/50Hz	72	63	42	60/55/33	4.6/3.3/2.3	2.44	2.57	165x150x140
LRP25-40/180	220~240/50Hz	73	64	43	64/58/35	4.6/4.3/3.9	2.55	2.71	195x150x140
LRP32-40/180	220~240/50Hz	69	60	41	60/54/37	4.3/4.0/3.4	2.73	2.89	195x150x140
LRP15-50/130	220~240/50Hz	85	60	40	40/32/23	4.5/3.8/2.5	2.32	2.45	165x150x140
LRP15-50B/130	220~240/50Hz	85	60	40	47/37/25	4.5/3.8/2.5	2.41	2.54	165x150x140
LRP20-50/130	220~240/50Hz	75	65	42	50/43/28	5.2/4.9/3.4	2.37	2.5	165x150x140
LRP25-50/130	220~240/50Hz	73	62	41	60/52/33	5.3/5.0/3.6	2.44	2.57	165x150x140
LRP25-50/180	220~240/50Hz	75	66	43	63/53/35	5.2/4.9/3.2	2.55	2.71	195x150x140
LRP32-50/180	220~240/50Hz	73	65	42	63/54/35	5.2/4.9/3.7	2.73	2.89	195x150x140
LRP15-60/130	220~240/50Hz	85	71	44	48/42/28	6.0/5.8/4.2	2.32	2.45	165x150x140
LRP15-60B/130	220~240/50Hz	85	71	44	48/42/28	6.0/5.8/4.2	2.41	2.54	165x150x140
LRP20-60/130	220~240/50Hz	96	69	45	53/37/25	5.5/4.5/2.8	2.37	2.5	165x150x140
LRP25-60/130	220~240/50Hz	83	70	43	58/43/28	5.5/4.5/2.8	2.44	2.57	165x150x140
LRP25-60/180	220~240/50Hz	83	69	44	68/60/35	6.1/5.8/4.5	2.55	2.71	195x150x140
LRP32-60/180	220~240/50Hz	85	77	44	66/58/38	5.9/5.5/4.1	2.73	2.89	195x150x140
LRP25-70/130	220~240/50Hz	150	130	105	67/50/37	6.3/6.0/5.2	2.45	2.61	165x150x140
LRP25-70/180	220~240/50Hz	150	130	105	67/50/37	6.3/6.0/5.2	2.57	2.73	195x150x140
LRP32-70/180	220~240/50Hz	150	130	105	67/50/34	6.3/6.0/5.2	2.75	2.91	195x150x140
LRP25-80/180	220~240/50Hz	200	190	160	120/100/60	7.1/6.5/5.5	4.23	4.57	196x196x160
LRP32-80/180	220~240/50Hz	270	245	160	167/100/60	7.3/6.7/5.4	4.75	5.09	195x196x160
LRP32-80F/220	220~240/50Hz	270	245	160	170/113/65	7.3/6.7/5.4	7.57	8	235x181x207
LRP36-80F/200	220~240/50Hz	270	245	160	170/113/65	7.3/6.7/5.4	5.98	6.36	214x170x190
LRP40-80F/250	220~240/50Hz	270	245	160	170/113/65	7.3/6.7/5.4	8.27	8.74	264x186x212
LRP25-120/180	220~240/50Hz	268	249	163	81/47/30	12/11/8	4.62	4.96	196x196x160

### Materials Table

No.	Part	Material
1	Rotor	
2	Thrust bearing adjusting mat	Noryl
3	Thrust ring support	Silicon rubber
4	Bushings	Graphite
5	Front bearing	Alumina
6	Pump support cover	Stainless steel
7	Check ball	Silicon rubber
8	Locking	Stainless steel
9	Impeller	PPO
10	Pump body	Cast iron/Bronze
11	Pump body insert	Stainless steel
12	Back bearing	Alumina
13	Can brg asm	Stainless steel
14	Can brg asm seal	Silicon rubber
15	Stator cover(front)	PA66
16	Stator	
17	Stator cover(back)	PA66
18	Housing	ADC12
19	Drain plug	Copper
20	Speed regulation board	
21	Terminal cover	ABS
22	Terminal box	PC
23	Capacitor	

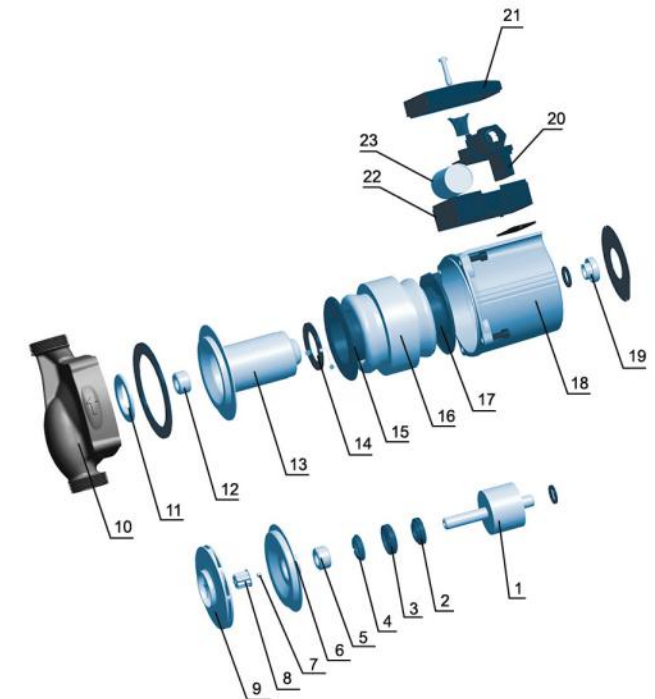



LEO<sup>®</sup> Hydraulic Performance Curves

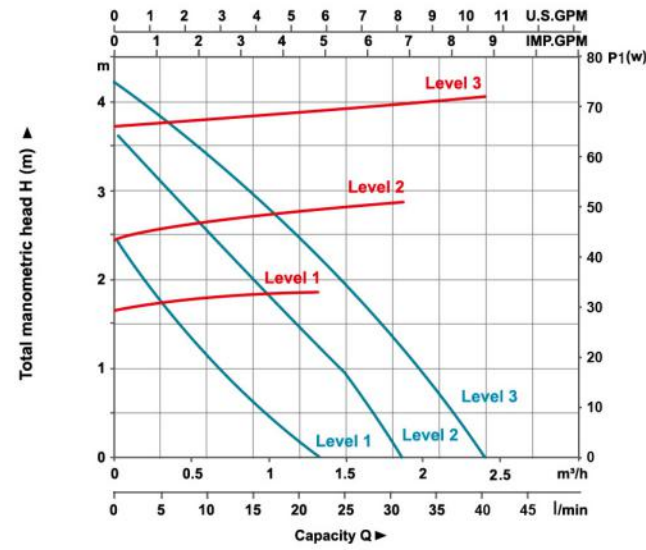

LRP15-40B/130  
LRP15-40/130  
— Q-H  
— Q-P

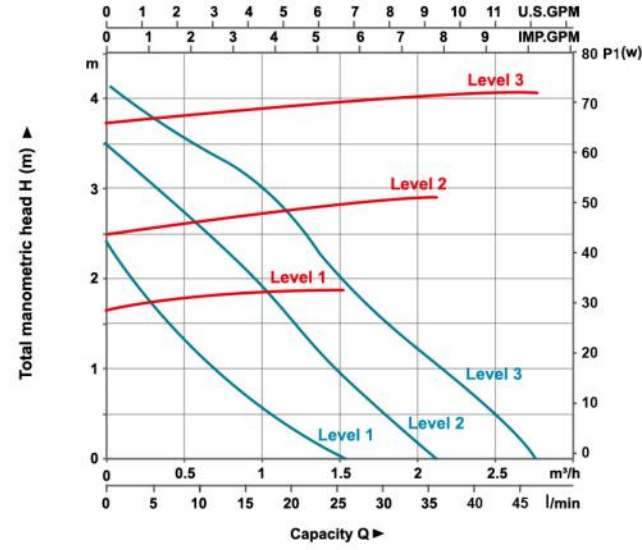

LRP20-40/130  
— Q-H  
— Q-P

Hydraulic Performance Curves

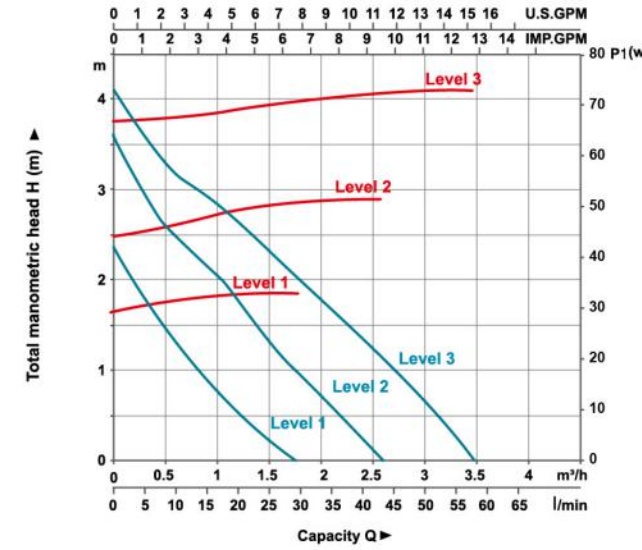

LRP32-40/180  
— Q-H  
— Q-P

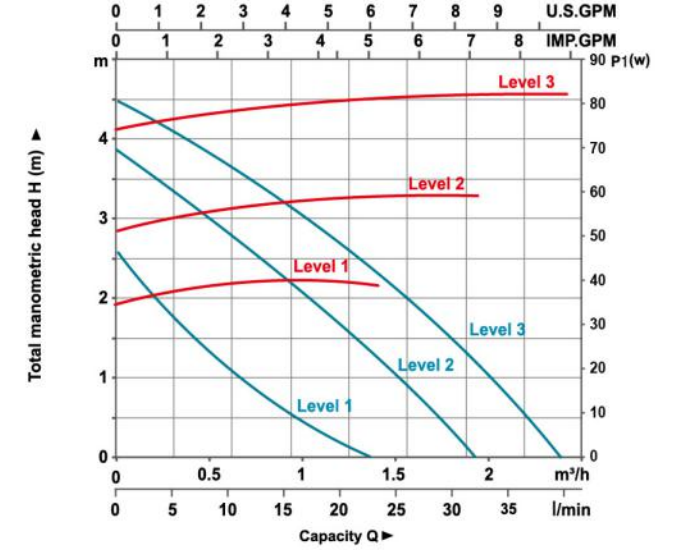

LRP15-50B/130  
LRP15-50/130  
— Q-H  
— Q-P

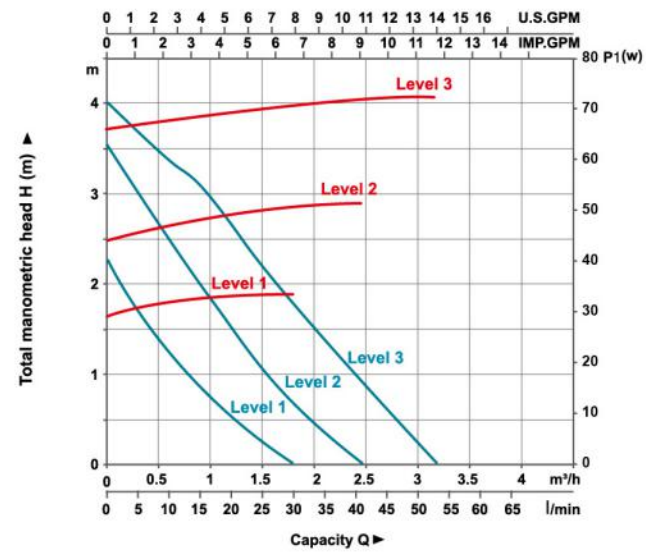

LRP25-40/130  
— Q-H  
— Q-P

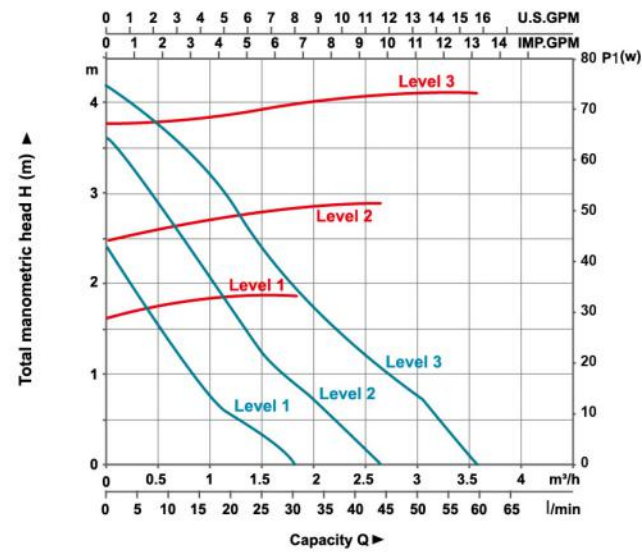

LRP25-40/180  
— Q-H  
— Q-P

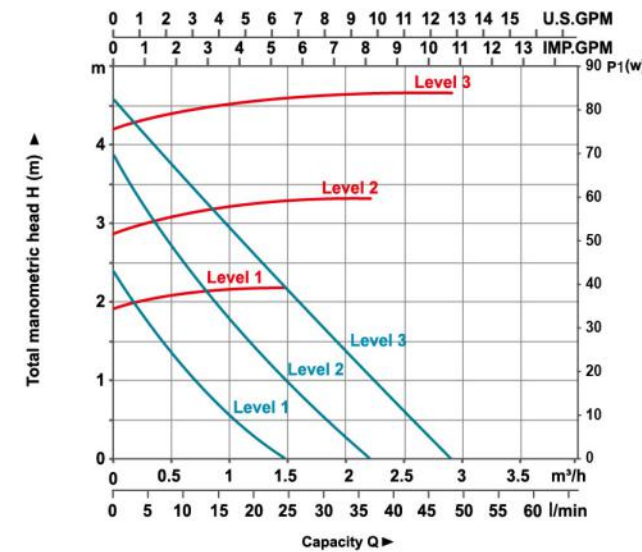

LRP20-50/130  
— Q-H  
— Q-P

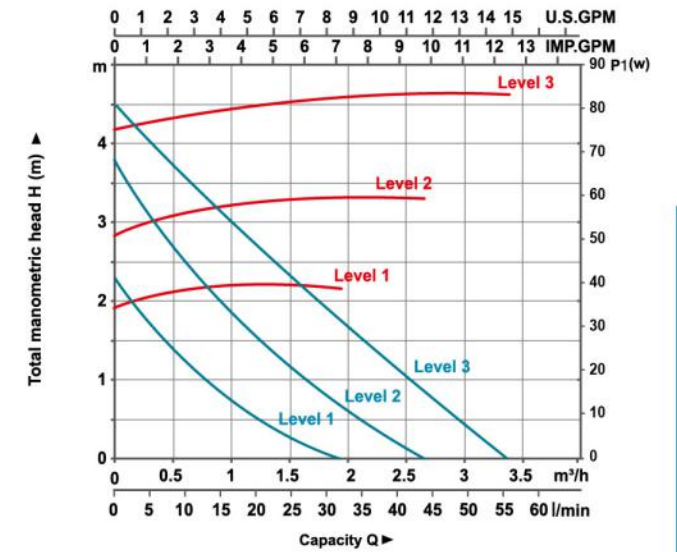

LRP25-50/130  
— Q-H  
— Q-P



LEO<sup>®</sup> Hydraulic Performance Curves

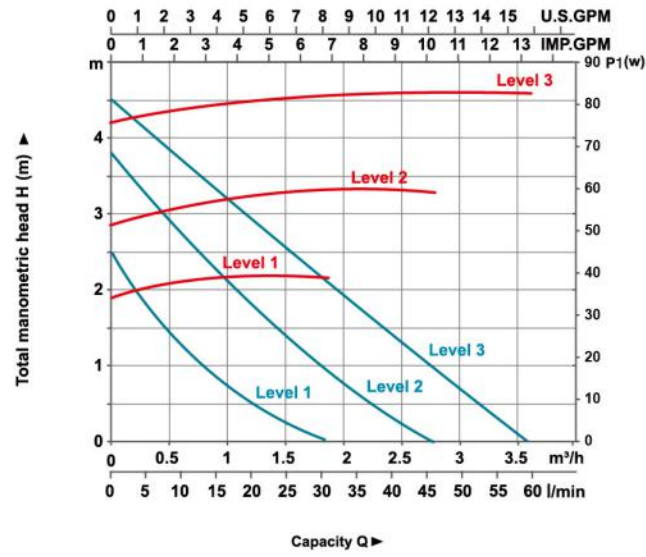

LRP25-50/180  
— Q-H  
— Q-P

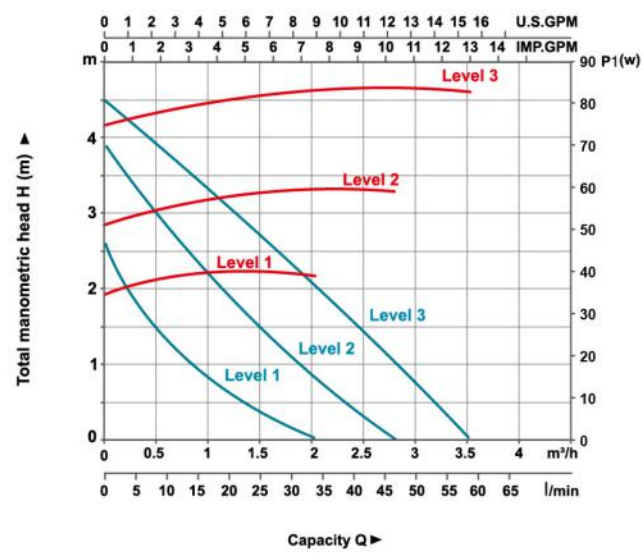

LRP32-50/180  
— Q-H  
— Q-P

Hydraulic Performance Curves

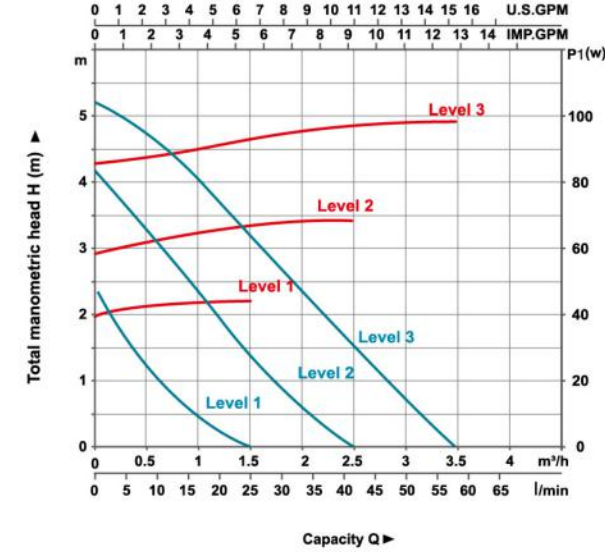

LRP25-60/130  
— Q-H  
— Q-P

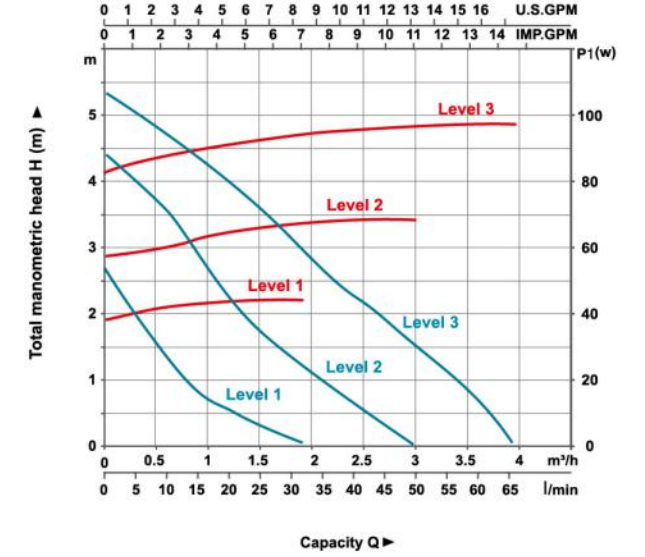

LRP25-60/180  
— Q-H  
— Q-P

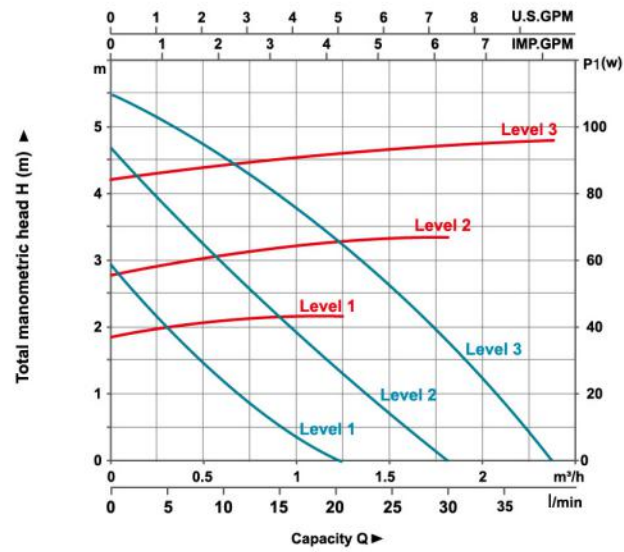

LRP15-60B/130  
LRP15-60/130  
— Q-H  
— Q-P

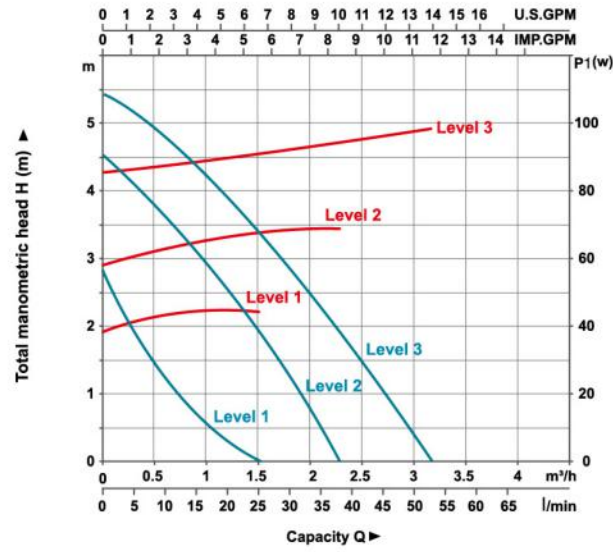

LRP20-60/130  
— Q-H  
— Q-P

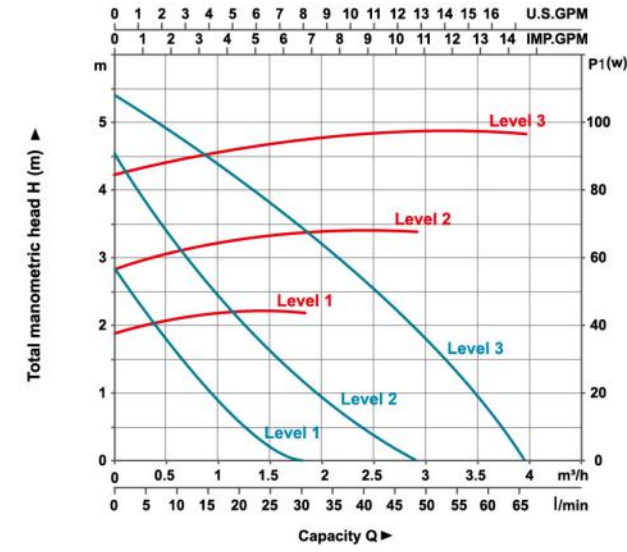

LRP32-60/180  
— Q-H  
— Q-P

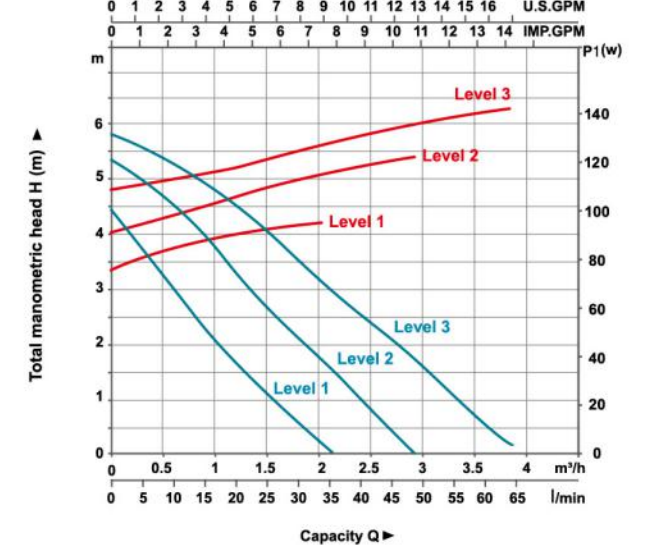

LRP25-70/130  
— Q-H  
— Q-P



LEO Hydraulic Performance Curves

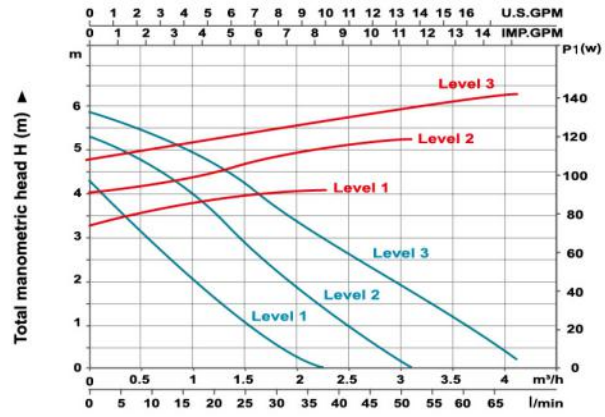

Capacity Q ►  
**LRP25-70/180**  
— Q-H  
— Q-P

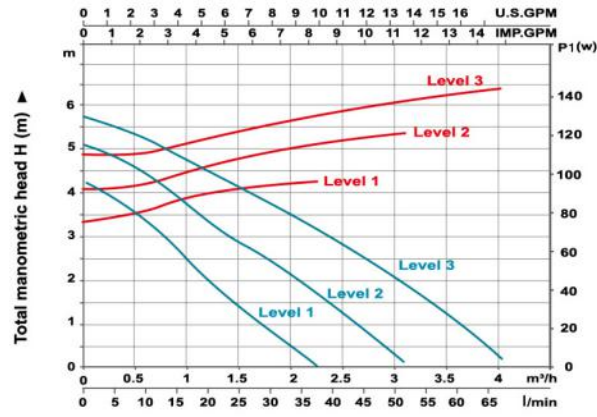

Capacity Q ►  
**LRP32-70/180**  
— Q-H  
— Q-P

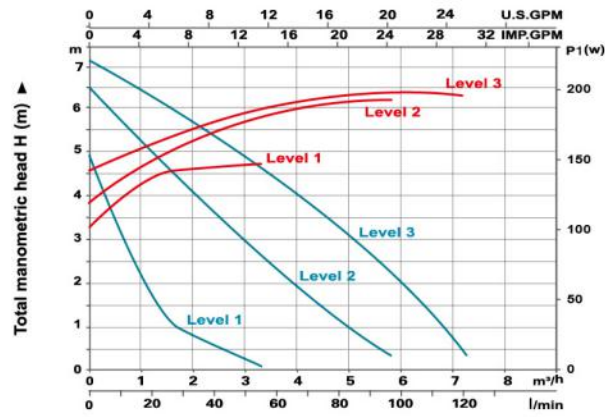

Capacity Q ►  
**LRP25-80/180**  
— Q-H  
— Q-P

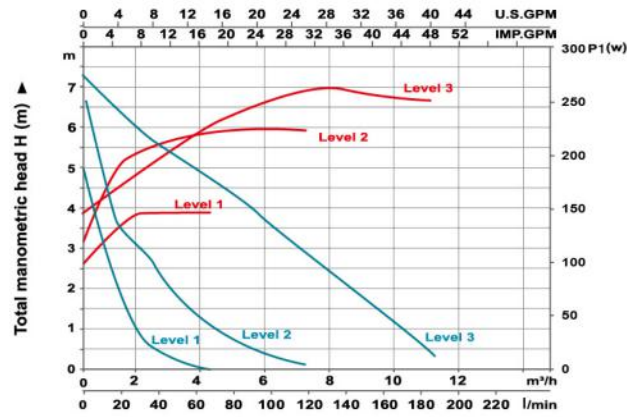

Capacity Q ►  
**LRP32-80/180**  
**LRP32-80/220**  
**LRP36-80/200**  
— Q-H  
— Q-P

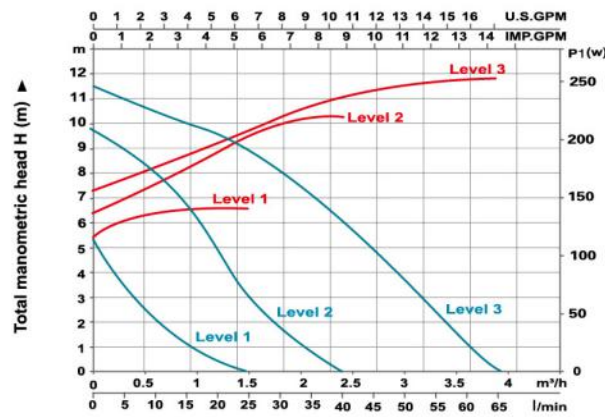

Capacity Q ►  
**LRP25-120/180**  
— Q-H  
— Q-P

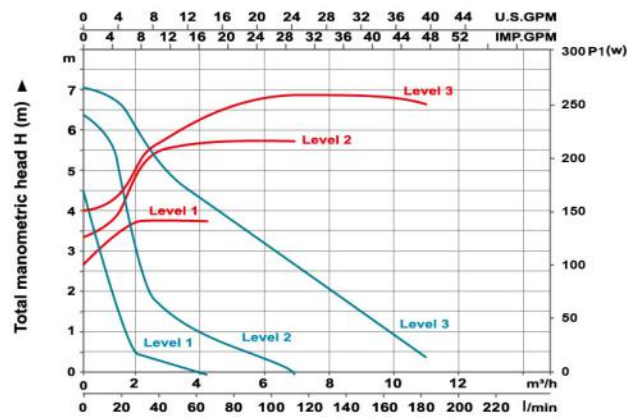

Capacity Q ►  
**LRP40-80F/250**  
— Q-H  
— Q-P

Application

- Can be used to transfer clean water or other liquids similar to water in physical and chemical properties
- Heating systems with constant or variable flows
- Heating systems with variable flow-pipe temperature
- Heating systems where night setback is desired
- Heating systems where the differential pressure of the pump is too high during periods of reduced flow demand
- Heating systems where requires a fully automatic adjustment of the performance to flow demands
- Pressure boosting of water heaters
- Circulation and pressure boosting of domestic water

Pump

- Compact design with perfect integrated control unit
- Anti-rust cast iron pump body
- Noryl impeller with heat resistant up to 150°C
- 95% alumina ceramic shaft
- Liquid temperature: 2°C to 110°C

Motor

- Insulation class: H
- Protection class: IP42
- 99% alumina ceramic bearing
- Copper winding
- Power /frequency(V/Hz): 220-240/50
- EEI: ≤ 0.23, which complies with the Eup Directive



Connectors on request



Identification Codes

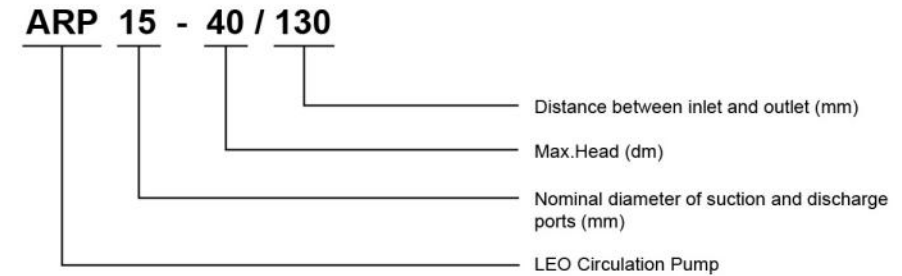



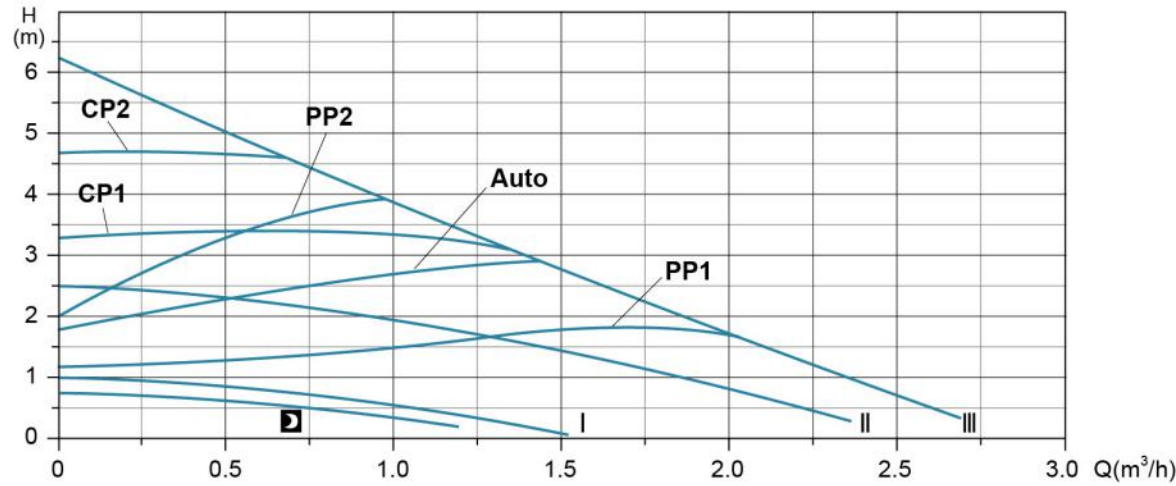
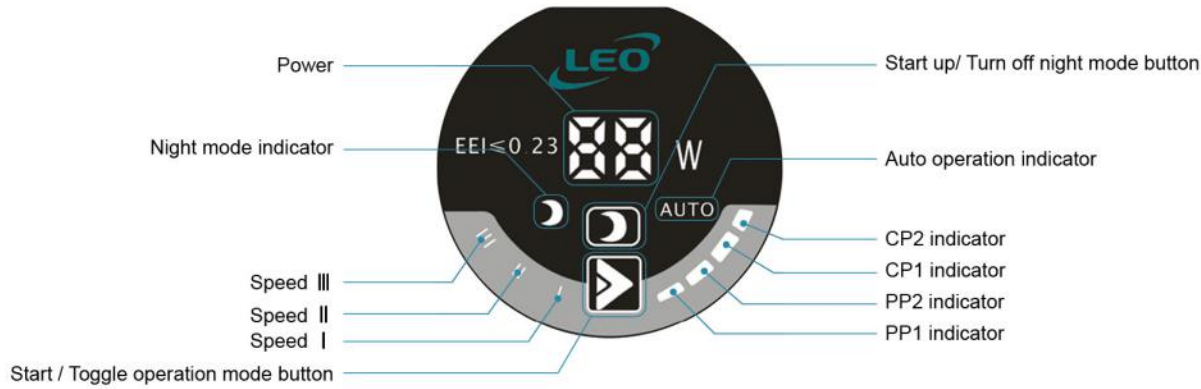

Mode	Pump Feature	Function
Auto	Max. to Min. proportional pressure curve	The auto adapt function enables the pump to control the performance to within a defined performance range. i.e. adjusting the pump performance to the size of the system and the variations in load over time. In this mode, the pump is set to proportional-pressure control.
PP1	Min. Proportion pressure curve	The duty point of the pump will move up or down on the lowest proportional pressure curve, depending on the heat demand in the system. The pressure is reduce at falling of heat demand and increased at demand rising.
PP2	Max. Proportion pressure curve	The duty point of the pump will move up or down on the highest proportional pressure curve, depending on the heat demand in the system. The pressure is reduce at falling of heat demand and increased at demand rising.
CP1	Max. constant pressure curve	The duty point of the pump will move out or in on the highest constant-pressure curve, depending on the heat demand in the system. The pressure is kept constant, irrespective of the heat demand.
CP2	Min. constant pressure curve	The duty point of the pump will move out or in on the lowest constant-pressure curve, depending on the heat demand in the system. The pressure is kept constant, irrespective of the heat demand.
III	Speed III	In speed III, the pump is set to run on the max. curve under all operating conditions. Quick venting of the pump can be obtained by setting the pump to speed III for a short period.
II	Speed II	In speed II, the pump is set to run on the intermediate curve under all operating conditions.
I	Speed I	In speed I, the pump is set to run on the min. curve under all operating conditions.
	Night mode	The pump changes to automatic night setback, i.e. minimum performance and power consumption, provided that certain conditions are met.

Technical Data

Model	Voltage /Frequency (V/Hz)	Max.Flow (m³/h)	Max.Head (m)	Power (W)	EEI	G.W. (kg)	Packing Size (mm)
ARP15-40/130	220-240/50	2	4.1	22	≤0.23	2.26	165x150x140
ARP15-50/130	220-240/50	2.3	5.2	32	≤0.23	2.26	165x150x140
ARP15-60/130	220-240/50	2.6	6.2	45	≤0.23	2.26	165x150x140
ARP20-40/130	220-240/50	2	4	22	≤0.23	2.33	165x150x140
ARP20-50/130	220-240/50	2.3	5.1	32	≤0.23	2.33	165x150x140
ARP20-60/130	220-240/50	2.6	6.1	45	≤0.23	2.33	165x150x140
ARP25-40/130	220-240/50	2.1	4	22	≤0.23	2.39	165x150x140
ARP25-40/180	220-240/50	2	4	22	≤0.23	2.56	195x150x140
ARP25-50/130	220-240/50	2.3	5	32	≤0.23	2.39	165x150x140
ARP25-50/180	220-240/50	2.3	5	32	≤0.23	2.56	195x150x140
ARP25-60/130	220-240/50	2.4	6.1	45	≤0.23	2.39	165x150x140
ARP25-60/180	220-240/50	2.7	6	45	≤0.23	2.56	195x150x140
ARP32-40/180	220-240/50	2.2	4	22	≤0.23	2.75	195x150x140
ARP32-50/180	220-240/50	2.5	5.1	32	≤0.23	2.75	195x150x140
ARP32-60/180	220-240/50	2.8	6.1	45	≤0.23	2.75	195x150x140

Performance Curve

Explain: ARPXX-40 curves ( Q-H, Q-P1 ) applies to the following models:

ARP15-40/130, ARP20-40/130, ARP25-40/130, ARP25-40/180, ARP32-40/180

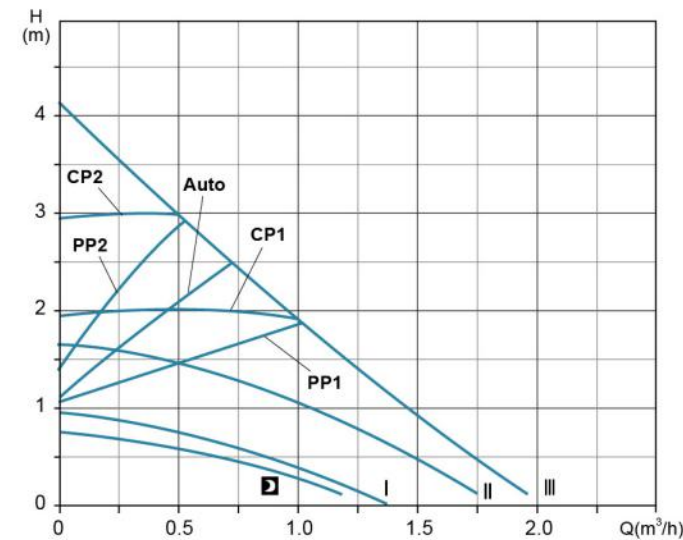

ARPXX-40 Q-H

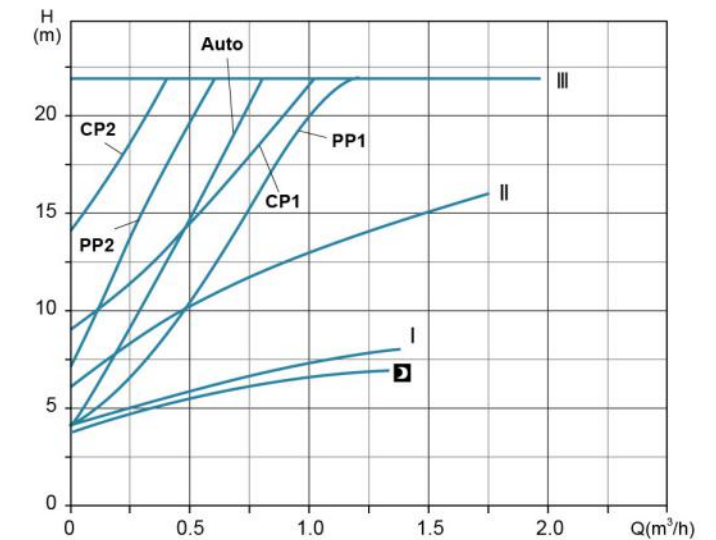

ARPXX-40 Q-P1



**Performance Curve**

**Explain:** ARPXX-50 curves ( Q-H, Q-P1 ) applies to the following models:

ARP15-50/130, ARP20-50/130, ARP25-50/130, ARP25-50/180, ARP32-50/180

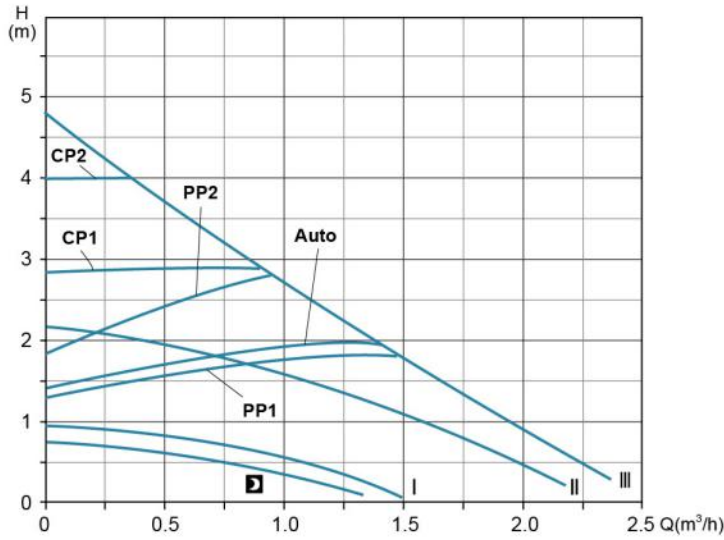

ARPXX-50 Q-H

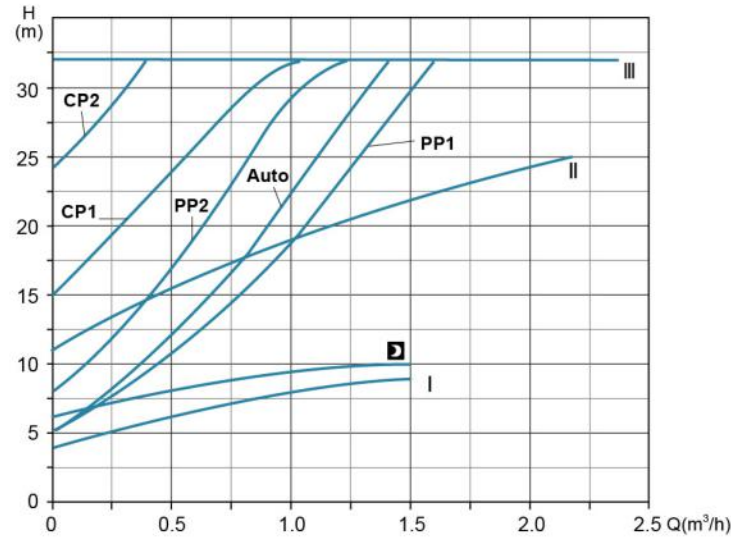

ARPXX-50 Q-P1

**Dimension**

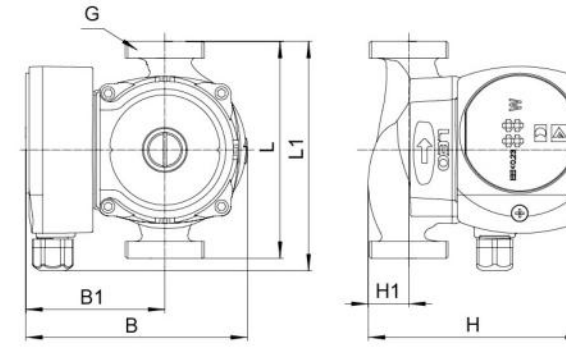

Model	L (mm)	L1 (mm)	B (mm)	B1 (mm)	H (mm)	H1 (mm)	G
ARP15-40/130	130	138	135	85	130	25	G1
ARP20-40/130	130	138	135	85	130	25	G1.25
ARP25-40/130	130	138	135	85	130	25	G1.5
ARP25-40/180	180	138	135	85	130	25	G1.5
ARP32-40/180	180	138	135	85	135	30	G2
ARP15-50/130	130	138	135	85	130	25	G1
ARP20-50/130	130	138	135	85	130	25	G1.25
ARP25-50/130	130	138	135	85	130	25	G1.5
ARP25-50/180	180	138	135	85	130	25	G1.5
ARP32-50/180	180	138	135	85	135	30	G2
ARP15-60/130	130	138	135	85	130	25	G1
ARP20-60/130	130	138	135	85	130	25	G1.25
ARP25-60/130	130	138	135	85	130	25	G1.5
ARP25-60/180	180	138	135	85	130	25	G1.5
ARP32-60/180	180	138	135	85	135	30	G2

**Explain:** ARPXX-60 curves ( Q-H, Q-P1 ) applies to the following models:

ARP15-60/130, ARP20-60/130, ARP25-60/130, ARP25-60/180, ARP32-60/180

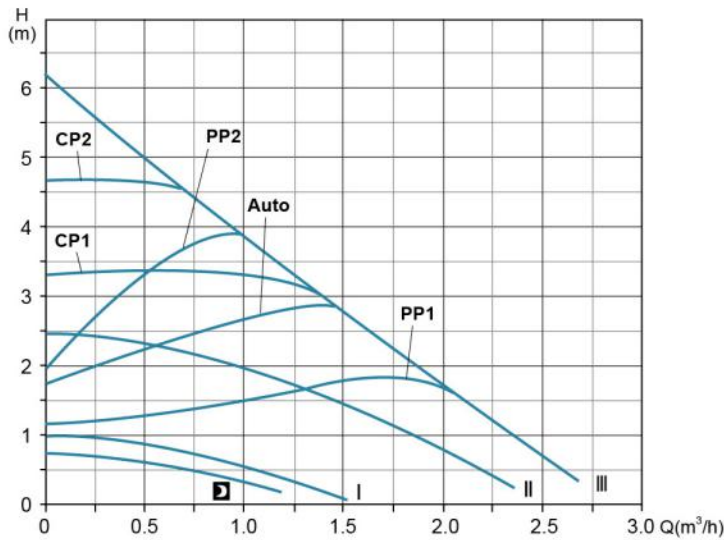

ARPXX-60 Q-H

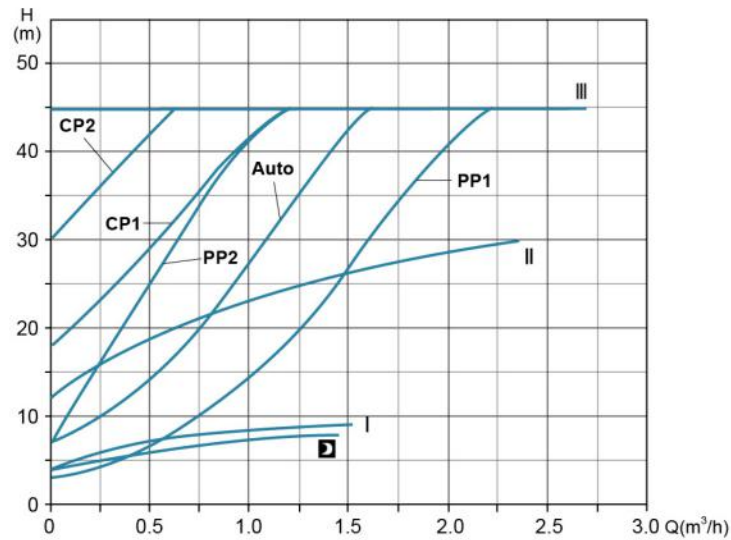

ARPXX-60 Q-P1

**Materials Table**

No.	Part	Material
1	Pump body	HT200/AISI304
2	Pump body inset	06Cr19Ni10
3	Body gasket	Silicon rubber
4	Impeller	PPO
5	locking	06Cr19Ni10
6	Check ball	Silicon rubber
7	Pump support cover	
8	Bushings	Graphite
9	Thrust ring support	Silicon rubber
10	Thrust bearing adjusting mat	PPO-GF30
11	Rotor	
12	Back bearing adjusting mat	PPO-GF30
13	Can brg asm	
14	O-ring	Rubber
15	Drain plug	DZR
16	Can brg asm seal	Silicon rubber
17	Stator sleeve	
18	Housing	ADC12
19	Bolt	
20	Nameplate	PC
21	Cable nut	ABS
22	Cable outlet nut	PA6-GF20
23	Washer	
24	Bolt	
25	Terminal cover	
26	Terminal box	
27	Terminal box seal	Rubber

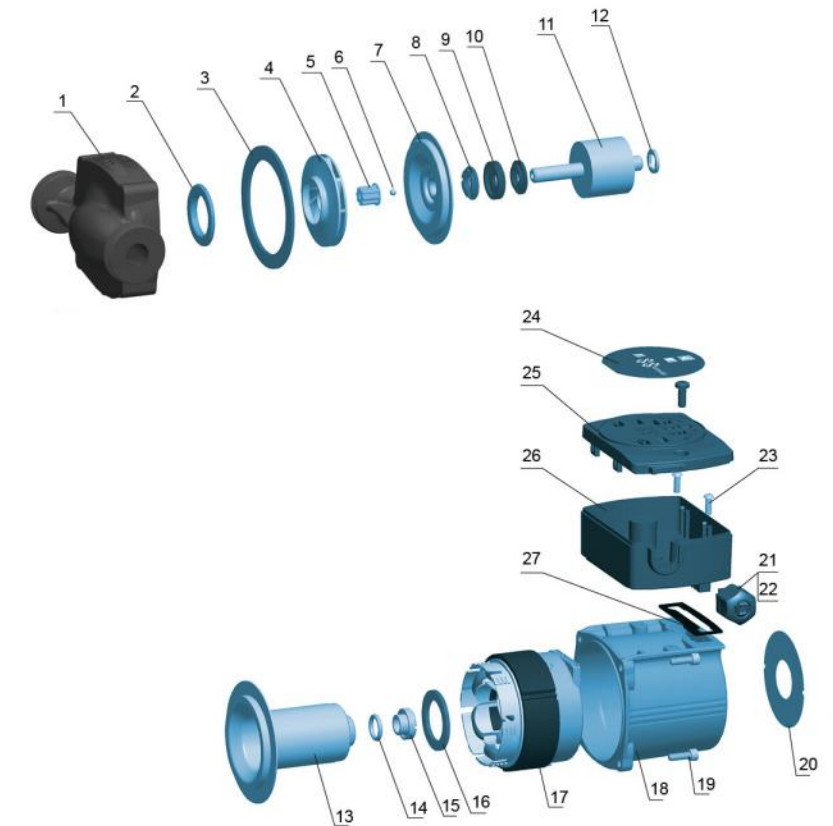





### Application

- It is widely used for
- Pressure boosting for domestic water supply
  - Floor heating system
  - Solar pumping system

### Pump

- Automatic pressure boosting
- Anti-rust cast iron pump body
- Noryl impeller with heat resistance up to 150°C
- 95% alumina ceramic shaft
- Liquid temperature: 2°C - 60°C

### Motor

- Insulation class: H
- Protection class: IP42
- 99% alumina ceramic bearing
- Copper winding

### Identification Codes

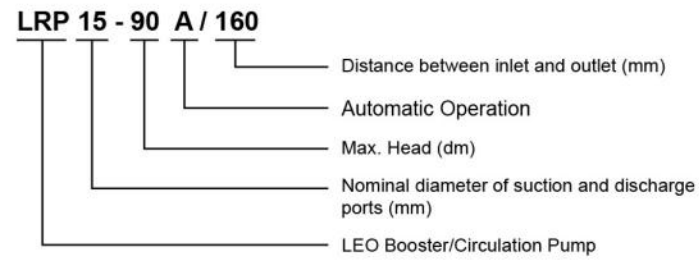

Connectors on request



### Hydraulic Performance Curves

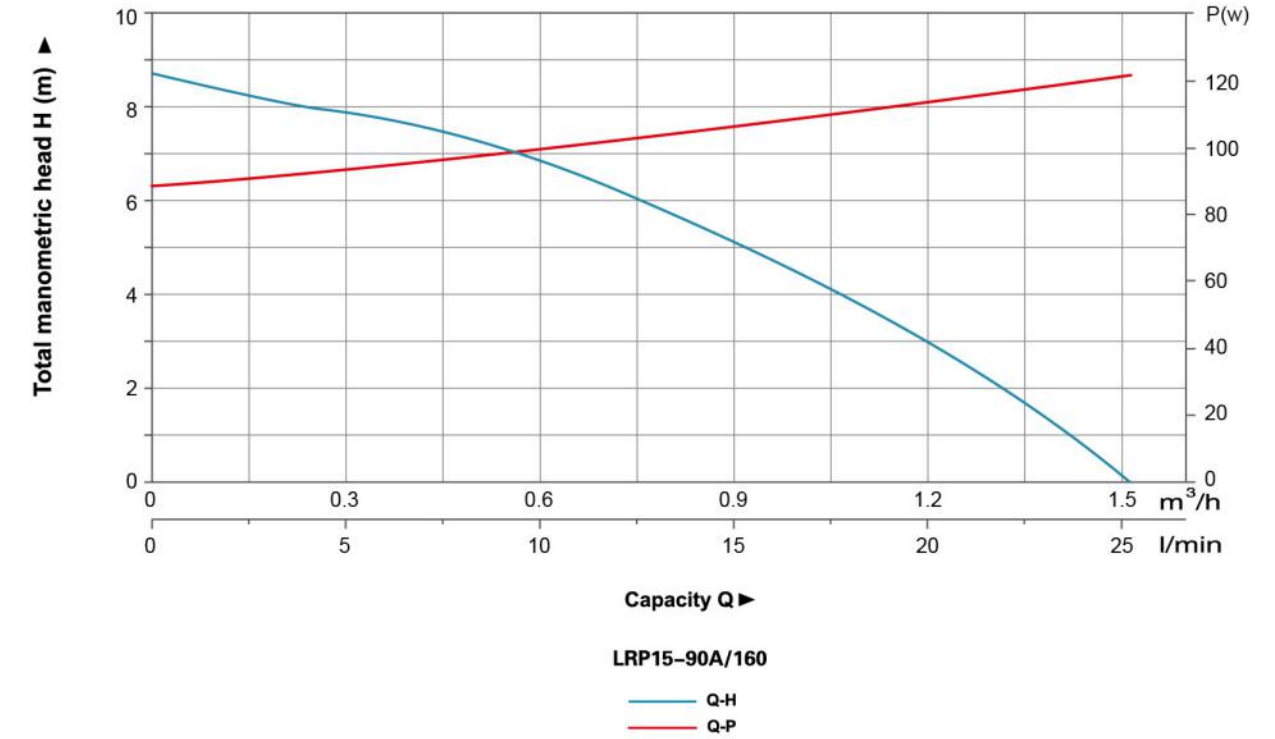

### Technical Data

Model	Voltage/Frequency	Power (W)	Max. Flow (l/min)	Max. Head (m)	N.W. (kgs)	G.W. (kgs)	Packing Size (mm)
LRP15-90A/160	1~230V/50Hz	120	25	9	2.72	2.74	198x143x160

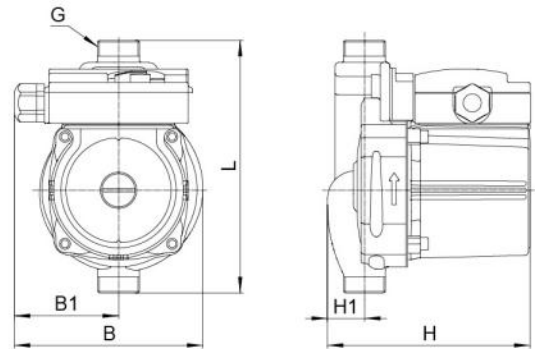

### Dimension Drawing

Model	L (mm)	B (mm)	B1 (mm)	H (mm)	H1 (mm)	G
LRP15-90A/160	160	120	70	130	25	G3/4

### Materials Table

No.	Part	Material
1	Rotor	
2	Thrust bearing adjusting mat	Noryl
3	Thrust ring support	Silicon rubber
4	Bushings	Graphite
5	Front bearing	Alumina
6	Pump support cover	Stainless steel
7	Check ball	Silicon rubber
8	Impeller	PPO
9	Pump body	Cast iron/bronze
10	Pump body insert	Stainless steel
11	Body gasket	
12	Rear bearing	HT200
13	Can brg asm	Stainless steel
14	Can brg asm seal	Silicon rubber
15	Stator cover(front)	PA66
16	Stator sleeve	
17	Stator cover(back)	PA66
18	Housing	ADC12
19	Cable outlet nut	ABS
20	Button	ABS
21	Terminal box	PA6
22	Regulation switch	
23	Capacitor	
24	Terminal cover	ABS
25	Flow switch assembly	







### Application

- It is widely used for heating/ventilating and air conditioning(HVAC) circulation, pressure boosting of hot water in family, homes powered by solar energy, industrial auxiliary equipment cold and hot water circulation and so forth
- Water circulation for the central and district heating system
- Domestic hot water circulation

### Pump

- Anti-rust cast iron pump body
- Noryl impeller with heat resistance up to 150 °C
- 95% alumina ceramic shaft
- Liquid temperature: 2 - 95 °C

### Motor

- Insulation class: H
- Protection class: IP44
- 99% alumina ceramic bearing
- Three speed motor

### Identification Codes

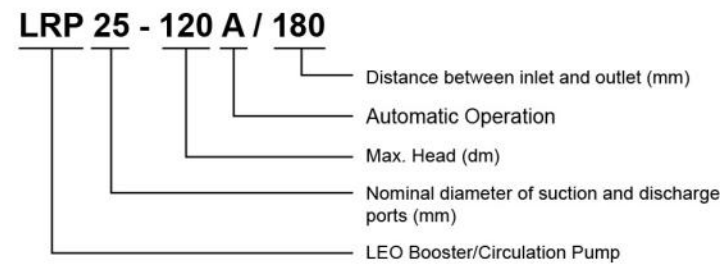

### Technical Data

Model	Voltage/Frequency	Input Power(W)			Max.Flow (l/min)	Max.Head (m)	N.W. (kgs)	G.W. (kgs)	Packing Size (mm)
		3	2	1					
LRP15-40A/130	220-240V/50Hz	74	54	34	38.3/30/21.7	4.2/3.6/2.4	2.32	2.45	198x143x160
LRP15-50A/130	220-240V/50Hz	85	60	40	38.3/30/21.7	4.5/4/2.6	2.32	2.45	198x143x160
LRP15-60A/130	220-240V/50Hz	96	69	45	38.3/28.3/21.7	5.5/4.7/3	2.32	2.45	198x143x160
LRP25-120A/180	220-240V/50Hz	270	200	160	58.3/45/25	12/11/3.5	4.62	4.96	192x170x190

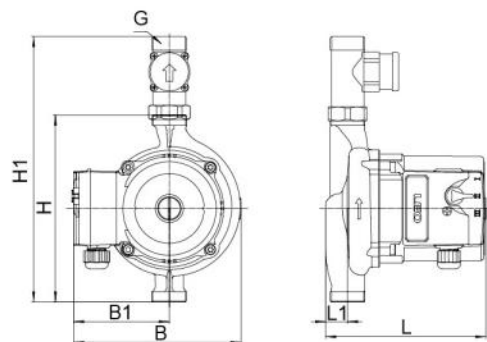

### Dimension

Model	L (mm)	L1 (mm)	B (mm)	B1 (mm)	H (mm)	H1 (mm)	G
LRP15-40A/130	130	205	125	75	130	25	G1
LRP15-50A/130	130	205	125	75	130	25	G1
LRP15-60A/130	130	205	125	75	130	25	G1
LRP25-120A/180	180	255	148	75	155	25	G1

### Hydraulic Performance Curves

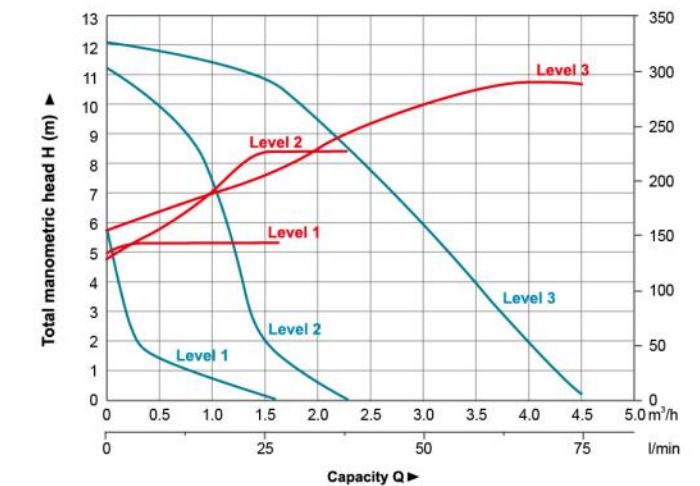
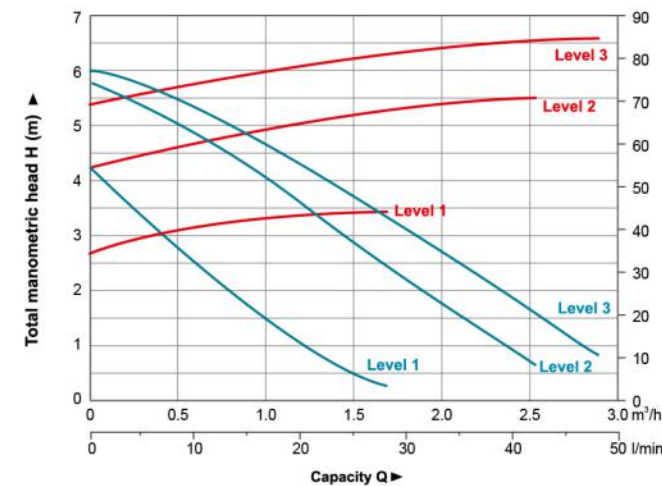
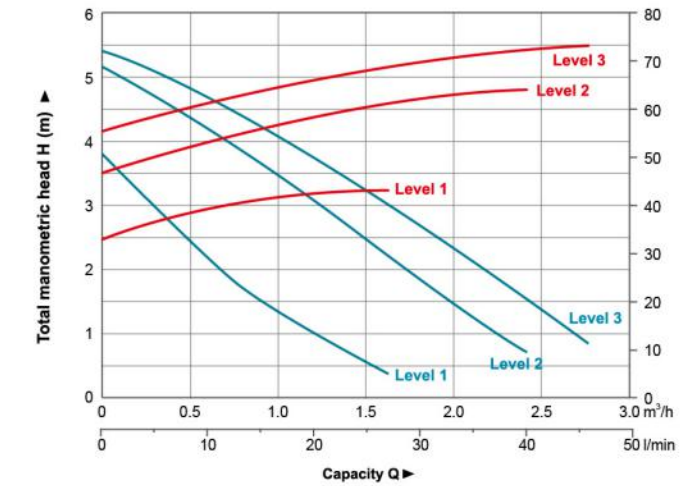
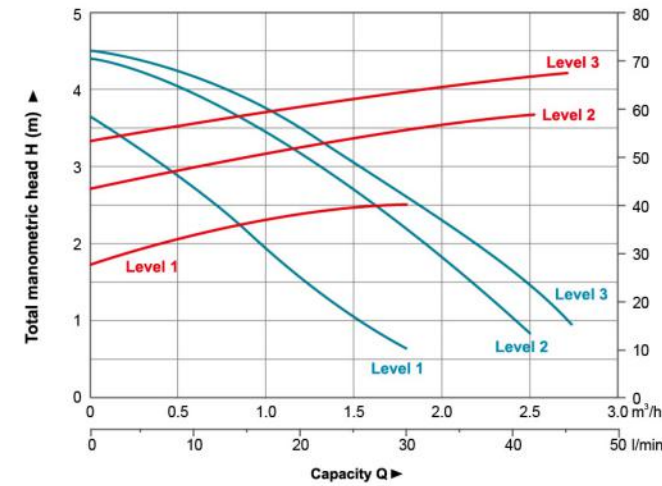

### Materials Table

No.	Part	Material
1	Back bearing adjusting mat	PPO-GF30
2	Rotor	
3	Thrust ring support	EPDM
4	Bushings	Graphite
5	Pump support cover	
6	Check ball	Silicon rubber
7	Locking	stainless steel
8	Impeller	
9	Pump body	Cast Iron
10	Pump body insert	stainless steel
11	Can brg asm	
12	Can brg asm seal	Silicon rubber
13	Stator sleeve	
14	Motor housing	ADC12
15	Drain plug	DZR
16	speed regulation board	
17	Terminal box cover	ABS
18	Capacitor	
19	Terminal box	PA6-GF20

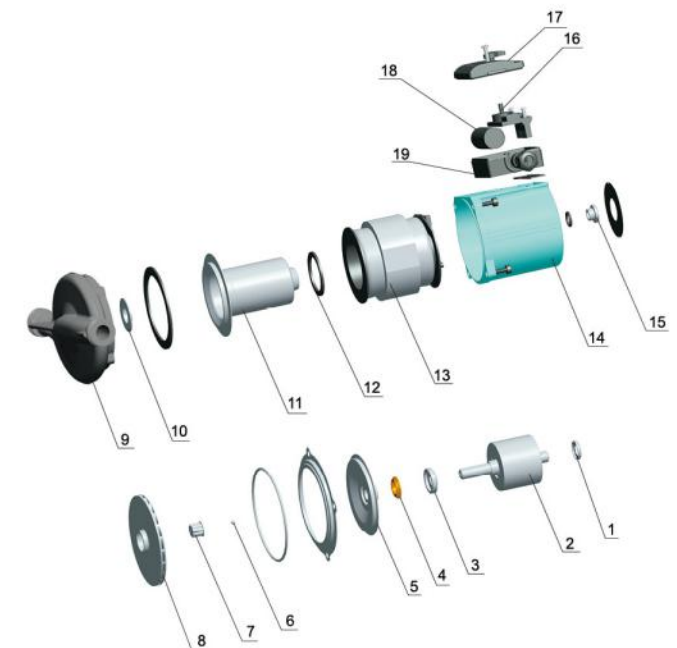





### Application

- It is suitable for boosting hot water powered by solar energy for sauna and bathing and solves insufficient water pressure in high-rise buildings.
- It can also supply water (less than 100°C) to two families.

### Pump

- Cast iron pump body and support under special anti-rust treatment
- AISI 304 shaft
- Liquid temperature: 2°C - 100°C

### Motor

- Insulation class: F
- Protection class: IP44

### Identification Codes

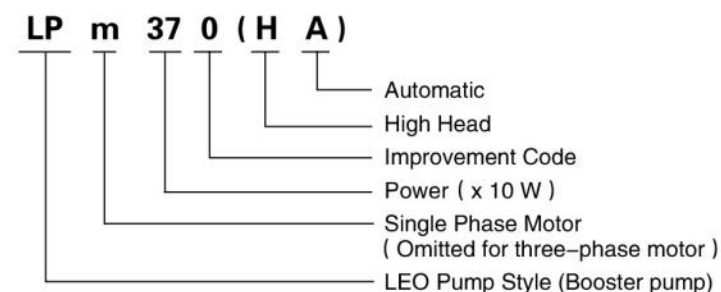

### Technical Data

Model	Power kW	Q(m³/h) Q(l/min)	H (m)														
			0	1.5	3	4.5	6	7.5	9	10.5	12	13.5	15	16.5	18	19.5	
LPm125	0.125	0	5.5	5	4.8	3.8	3	1.7	-	-	-	-	-	-	-	-	-
LPm250	0.25	0	5.5	5.2	5.1	4.9	4.6	4.2	3.5	2.8	2	-	-	-	-	-	-
LPm370	0.37	0	8	7.9	7.8	7.5	7.2	6.7	6.2	5.6	4.8	4	3.3	2.3	-	-	-
LPm550	0.55	0	19	19	18.9	18	17	16	14.9	13.7	12.4	11.2	9.8	8.5	6.6	4	-

Model	Power kW	Q(m³/h) Q(l/min)	H (m)														
			0	0.6	1.2	1.8	2.4	3.0	3.6	4.2	4.8	5.4	6.0	6.6			
LPm370HA	0.37	0	21	20.6	18.5	16	13.4	10	5.5	-	-	-	-	-	-	-	-
LPm750HA	0.75	0	30.8	30.7	30	29.5	28.3	26.3	24.4	22	19	16.2	13.2	9.4	-	-	-

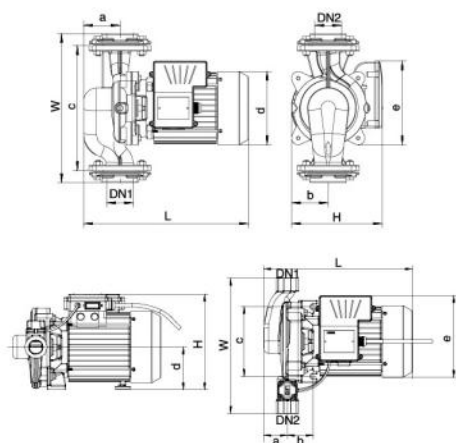

### Dimension

Model	DN1	DN2	L (mm)	W (mm)	H (mm)	a (mm)	b (mm)	c (mm)	d (mm)	e (mm)
LPm125	1 1/2"	1 1/2"	275	260	186	47	74	210	Φ141	160
LPm250	2"	2"	301	313	190	71	78	260	Φ141	164
LPm370	2 1/2"	2 1/2"	367	334	195	77	84	280	Φ141	173
LPm550	2"	2"	369	344	210	81	87	280	Φ165	182
LPm370HA	1"	1"	295	270	209	43	60	124	Φ95	141
LPm750HA	1"	1"	341	310	220	54	59	160	Φ98	165

### Hydraulic Performance Curves

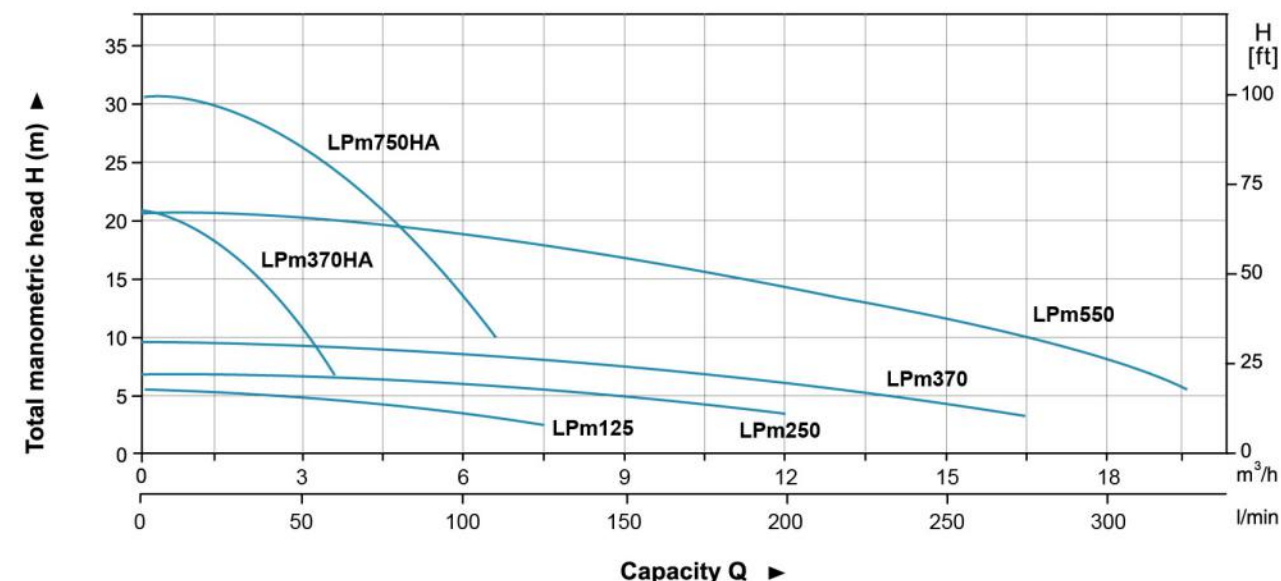

### Materials Table

#### LPm125/LPm250/LPm370/LPm550

No.	Part	Material
1	Flange	HT200
2	Pump body	HT200
3	Flange gasket	
4	Impeller	PPO
5	Machanical seal	Carbon/Ceramic
6	O ring	
7	Support	HT200
8	Bearing	
9	Rotor	
10	Stator	
11	Terminal box	ABS
12	Capacitor	
13	Terminal box cover	
14	Rear cover	ZL102
15	Fan	PP
16	Fan cover	08F

#### LPm370HA/LPm750HA

No.	Part	Material
1	Pump body	HT200
2	Impeller	PPO
3	O ring	
4	Support	HT200
5	Bearing	
6	Rotor	
7	Machanical eel	Carbon/Ceramic
8	Control switch	
9	Stator	
10	Terminal box Capacitor	ABS
11	Terminal box cover	
12	Rear cover	
13	Fan	ZL102
14	Fan cover	PP
15	Fan	08F
16	Fan cover	08F

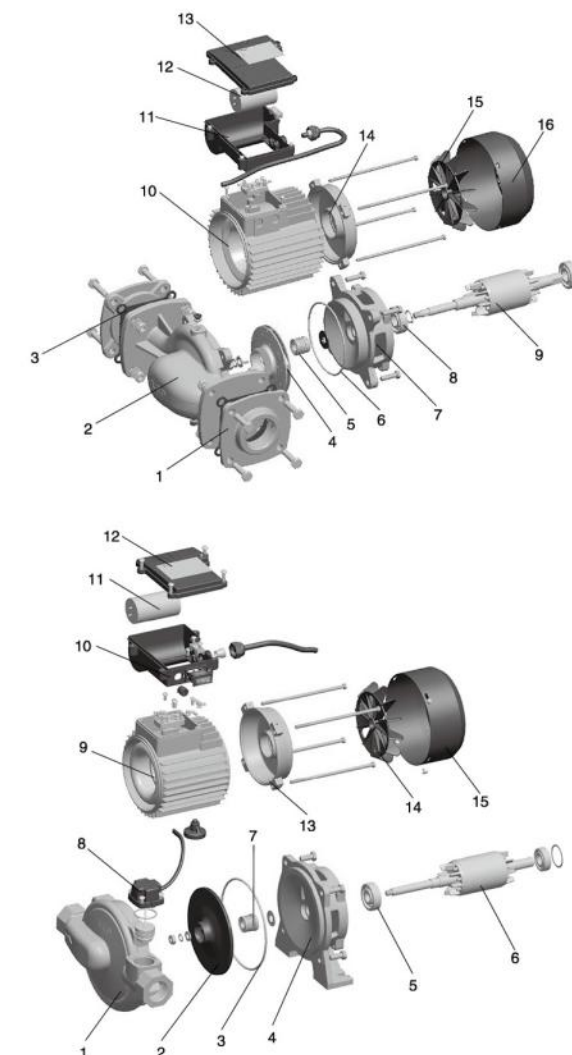





Three-phase



Single-phase

### Application

- Hot water circulation and heating system
- Air-conditioning system
- Industrial circulation system
- General pressure boosting in household

### Pump

- Cast iron pump body and support under special anti-rust treatment
- AISI 304 shaft
- Liquid temperature: 2°C - 100°C

### Motor

- Insulation class: B
- Protection class: IP44

### Identification Codes

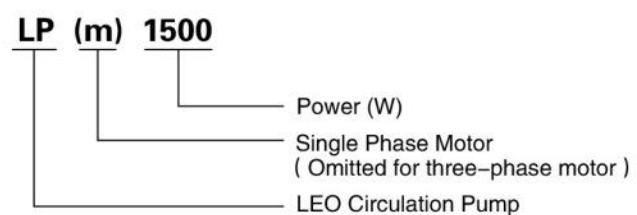

### Technical Data

Model	Power		Q(m <sup>3</sup> /h)	Q(l/min)											
	kW	HP		0	6	9	12	15	18	21	24	30	32		
LP(m)1500	1.2	2	H (m)	36	25	24	23	21	19	17	13	5	0		
LP(m)2200	2.2	3		34	33	32	30	28	26	23	20	12	8		

### Dimension

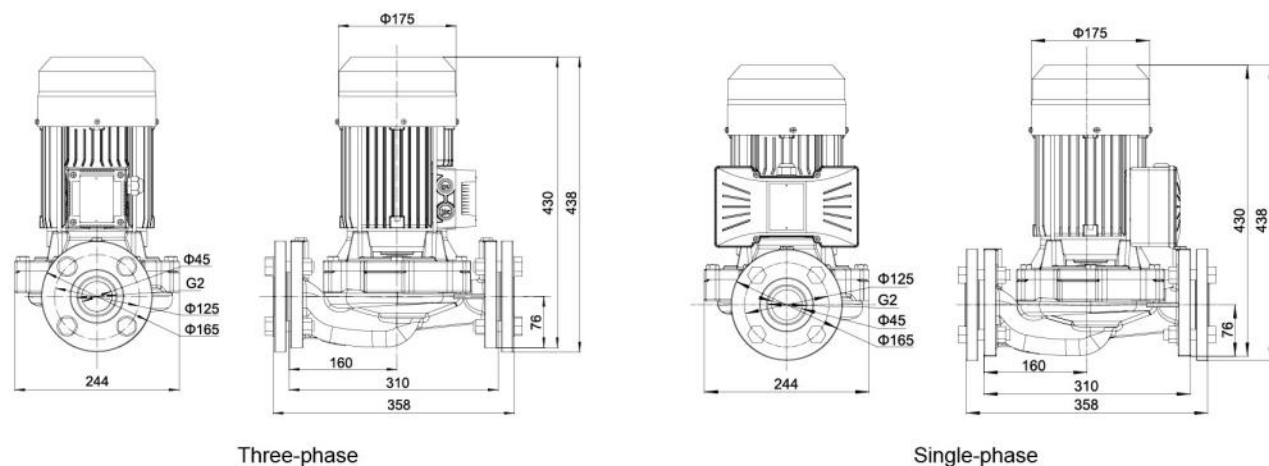

### Hydraulic Performance Curves

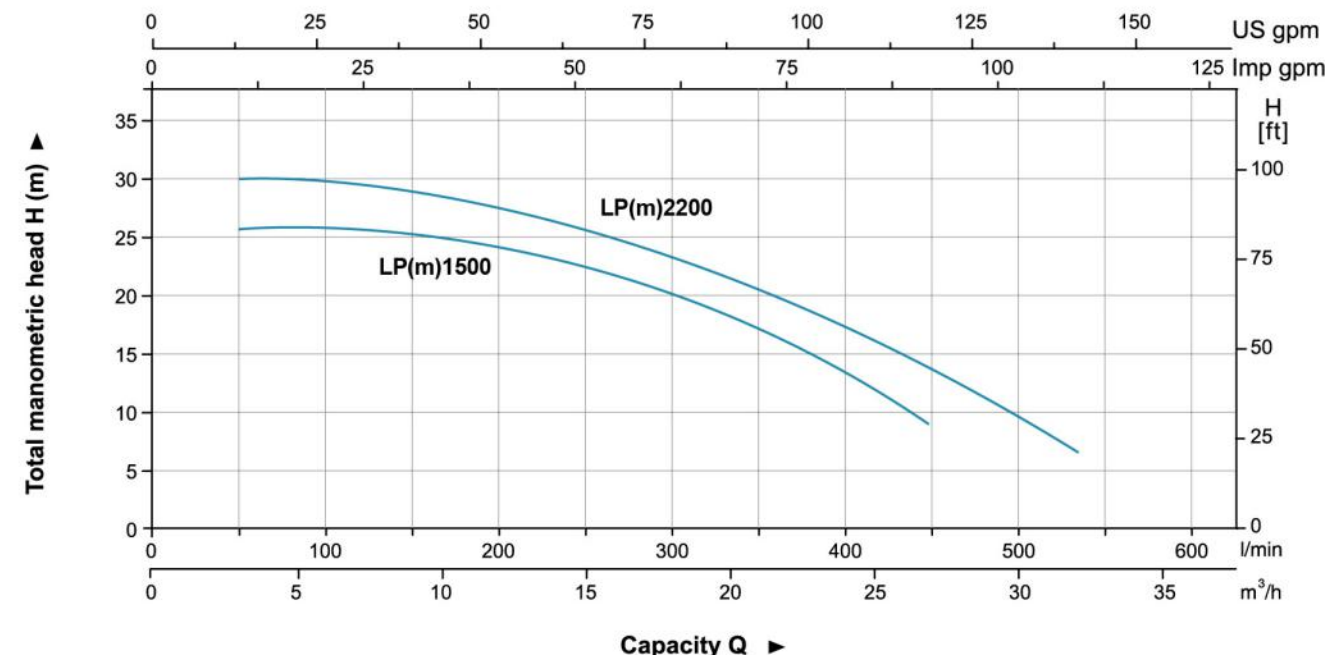

### Materials Table

No.	Part	Material
1	Flange	HT200
2	Pump body	HT200
3	Impeller	Brass
4	Support	HT200
5	Bearing	
6	Rotor	
7	Fan cover	08F
8	Fan box	PP
9	Terminal box	ABS
10	Rear cover	ZL102
11	Stator	ABS
12	Capacitor	

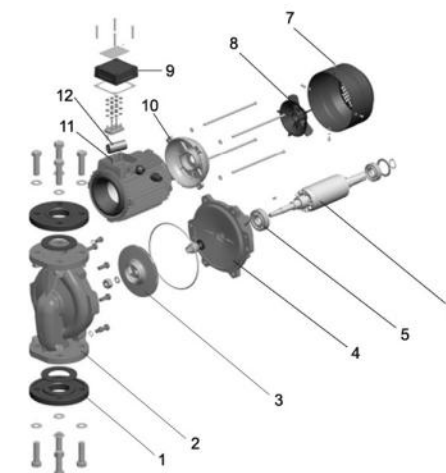

### Package Information

Model	G.W (kg)	L (mm)	W (mm)	H (mm)
LP(m)1500	37	450	325	375
LP(m)2200	38.8	450	325	375

